

A STEM FUTURE: SUITABLE FOR STUDENTS AGED 9-11

Future world

STEM Learning activity resources

SUBJECT LINKS:

Science, mathematics, design and technology, computing and essential employability skills.



A STEM FUTURE: SUITABLE FOR AGE 9-11

Future world

STEM Learning activity resources

Introduction

This programme has been created by STEM Learning, the largest provider of STEM education and careers support in the UK. It has been developed in partnership with STEM Club leaders and supports essential employability skills and the Gatsby Careers Benchmarks.

Future world

What does the future hold? From what we wear, how we get our energy and even what we eat—there's always room for innovation. In this programme, pupils will explore technology and its possible applications in the future, with an emphasis on sustainability. Many of the activities could contribute toward becoming an Eco School.

Key information

AGE RANGE: 9–11

SUBJECT LINKS: Science, mathematics, design and technology, computing

DURATION: Activities range from 20 to 90 minutes – at least 6 hours in total.

FLEXIBILITY: Complete the whole programme over a half term or choose individual activities to suit the needs of your Club.

RESOURCES: Each activity includes a list of the resources required and a comprehensive set of Club leader and pupil notes in the form of guides.

ESSENTIAL SKILLS: Each activity identifies essential employability skills as recognised by the Skills Builder Framework

IMPACT MEASUREMENT: Each set of resources is designed to help evaluate and assess the progress of Club-based learning on Club members. A useful set of assessment tools are available at www.stem.org.uk/enrichment/stem-clubs

ACHIEVEMENT: Pupils that successfully complete an entire set of activities can be rewarded with the downloadable STEM Clubs Certificate of Achievement. Students may be able to use these resources to work towards a CREST Discovery Award.

APPROPRIATE VENUES: Club leaders can run most activities in general spaces e.g. classrooms, halls, and outdoor areas. If not, suggested locations are marked clearly in the Club leader guide and in the table below.

SAFETY: Each activity includes details about significant health and safety considerations, such as appropriate eye protection, gloves, etc. Club Leaders should ensure that all equipment is handled with care, particularly sharp instruments. Advice and guidelines are available from CLEAPSS and SSERC, or see the STEM Clubs handbook (page 20). We recommend that practical activities are risk assessed before commencing and Club Leaders must follow their employer or organisations policies.

OTHER ACTIVITIES: Visit www.stem.org.uk/resources/stem-clubs/ for a wealth of ideas for STEM-related Clubs.

FURTHER SUPPORT: The STEM Clubs Best Practice Handbook can be found at www.stem.org.uk/stem-clubs/getting-started A selection of careers information, resources, programmes and guidance can be found at www.stem.org.uk/stem-careers



Activities

1	POCKET SIZED POWER: pupils explore how movement is used to generate electricity by making their own simple generator.	🕒 45 minutes	Page 4
2	DOES MY OUTFIT LOOK RUBBISH?: pupils discover what materials our clothes are made from, and how they could be recycled.	🕒 60 minutes	Page 7
3	FUTURE CLOTHING: pupils explore wearable technology with lights and LEDs, and create their own designs.	🕒 60 minutes	Page 11
4	DRONE PILOT: pupils build and programme a simple drone and steer it through a maze.	🕒 60+ minutes	Page 15
5	SOUNDS DELICIOUS: carry out an investigation to see whether the frequency of sounds we listen to affect our taste buds.	🕒 60 minutes	Page 18
6	GRASSHOPPER BURGER ANYONE?: pupils carry out a survey to see what people think about some of the possible things we might be eating in the future.	🕒 30 minutes	Page 22
7	THROUGH THE KEYHOLE: pupils simulate keyhole surgery to find out about how modern surgeons carry out operations without having to open the patient up, and explore how robots are changing surgery.	🕒 45 minutes	Page 26
8	ELECTRICAL DOUGH: pupils create insulating and conductive dough and use it to build 'squishy' circuits.	🕒 60 minutes	Page 30
9	SKILLS BUILDER FRAMEWORK: Introduction to the Framework that uses essential employability skills to develop student learning across four key domains: interpersonal, self-management, creative problem-solving and communication skills.		Page 36

CLUB LEADER GUIDE: SUITABLE FOR AGE 9-11

Future World

1 Pocket sized power

Objective

In this activity pupils will explore how you can turn movement into electricity by making a simple generator.

TOPIC LINKS

- 🔗 Science: electricity
- 🔗 Design and Technology: design and make a working dynamo generator

ESSENTIAL SKILLS SUPPORTED

Problem solving, staying positive, teamwork

TIME

🕒 45 minutes

RESOURCES AND PREPARATION

- magnetic wire – roughly 50 metres per group
- block or bar magnets
- corrugated cardboard
- crocodile clips
- one 1.5V bulb and bulb holder per group
- long, thin wooden dowels
- scissors and tape

HEALTH AND SAFETY:

A suitable risk assessment must be carried out by the activity leader and any significant findings recorded: if carried out in schools, guidance from CLEAPSS or SSERC must be used where appropriate.

Magnetic wire can be very sharp and should be handled with care. Make sure that groups are properly supervised and that the children understand the dangers associated with working with wire.

DELIVERY

- 1 Ask the students if they know how electricity is generated. They might talk about burning fossil fuels, using wind turbines or some other power production method. Explain that this is part of how electricity is generated, but it's not the whole story. How does burning coal become electricity? How does a spinning wind turbine become electricity?

Note: Electricity is not made, it is only generated. Electricity is one form of energy. When electricity is generated, one form of energy is being turned into another form of energy – electricity. Energy cannot be made or destroyed, only changed from one form into another – as per the First Law of Thermodynamics.

- 2 Explain to the children that magnets are used to generate electricity. When magnets are moved through or around a coil of magnetic copper wire, the magnetic field of the magnet interacts with the electrons in the wire. This causes the particles in the wire to move, creating a current of electricity. Magnetic energy and kinetic (movement) energy are combined to generate electrical energy.
- 3 To better understand how this works, the children are going to make their own simple electrical generators to turn mechanical energy (which is the combination of kinetic and potential energy) into electrical energy!
- 4 Make a generator (see the student guide for details, or refer to this link www.wikihow.com/Make-a-Simple-Electric-Generator explaining how it works).

TIPS

- The more wire is coiled around the outside of the cardboard, the easier it will be to make the bulb glow. Using stronger magnets will also make the generator work more easily. If you are still having trouble seeing the bulb glow, try turning the lights out in the classroom and testing the generators in the dark.
- It may be easier and safer if you complete some of the cutting tasks for the children, especially removing the plastic protection from the ends of the magnetic wire using scissors.
- We suggest printing or allowing the pupils to view online this set of easy to follow directions and diagrams. <https://www.wikihow.com/Make-a-Simple-Electric-Generator>



EXTENSION IDEA



- 1 Solar panels use the sun's rays to generate electricity, however they do not use the standard magnet and copper wire set up that we have looked at so far. Spend some time researching solar energy and discover how this green form of energy works

DIFFERENTIATION IDEAS

Support: complete steps 1 – 5 of the pupil guide for the group beforehand. They can coil the wire around the generator and connect the bulb to the generator while you explain the physics behind this type of electricity generation.

Challenge: encourage students to design their own dynamo after having the basic concept of electrical generation explained to them (i.e. that they need to have a spinning magnet inside a coil of magnetic wire).

USEFUL LINKS

-  [How to make a simple generator](http://amasci.com/coilgen/generator_1.html)
http://amasci.com/coilgen/generator_1.html
-  [The world's first electrical generator](http://www.youtube.com/watch?v=NqdOyxjZj0U)
www.youtube.com/watch?v=NqdOyxjZj0U
-  [A video explaining the basics of electromagnetism and Faraday's accomplishments](http://www.youtube.com/watch?v=32_3Um3a65s)
www.youtube.com/watch?v=32_3Um3a65s



Future World

1 Pocket sized power

Briefing



Exploring jungles and trekking mountains can quickly become a dangerous and isolating experience when using today's technology. GPS trackers can stop working, phones can die and flashlights can run out of battery, leaving an intrepid explorer to face the dangers of the wild on their own. However, you won't be caught off guard after this lesson, as you're going to learn how to make your own electrical generator!

YOUR TASK Explore how electricity is generated and then make your own simple generator.

WHAT YOU NEED TO DO

- 1 Cut a piece of corrugated cardboard into an 8cm by 30cm piece. Score and fold this cardboard into cuboid. (When scoring the cardboard, make sure that you mark out three large sides and two small sides. Two of the large sides will overlap when you fold the cardboard into a cuboid. These sides can then be stuck together, helping to keep your generator strong and stable.)
- 2 Make sure that your magnet fits comfortably inside the cuboid. If you need to, make your cardboard cuboid larger.
- 3 Poke holes in the centre of the large sides of the cardboard using scissors. Be very careful when doing this. These holes should be big enough for your wooden dowel to fit through.
Tip: Draw a line from one corner of the large side of the cuboid to the opposite corner. Do this for the other two corners as well to create an X shape. The middle of this X shape will be the centre of that side of the cuboid.
- 4 Poke the wooden dowel through both sides of your cardboard cuboid and make sure that the cardboard can spin on the dowel. If it doesn't spin, you may need to make the holes in the cardboard slightly bigger.
- 5 Place the magnets inside the cardboard cuboid and attach them to the wooden dowel using sticky tape. The magnets will need to all be facing the same way,

otherwise they will repel each other. Check again to make sure that your generator still spins freely.

- 6 Wrap your magnetic wire around the cardboard cuboid at least 200 times (nearer 300 times would be better). Make sure not to cover the gaps in the cuboid or get too close to the holes for the wooden dowel, as this may stop the generator from being able to spin. Don't wrap the wire too tight, as this may squeeze the cardboard and also stop the generator from being able to spin.
- 7 Leave the two ends of the wire facing in the same direction. Make sure that there is no plastic covering the last 3cm or 4cm of wire at each end. You may need to ask your Club leader to do this using a pair of scissors.
- 8 Attach the ends of the wire to the bulb holder using the crocodile clips. Twist the ends of the wire around the bottom loop of the crocodile clip and then attach the clips to the bulb holder.
- 9 When everything is in place, spin the magnets inside the cardboard using the wooden dowel. The bulb should begin to give out light. You will need to spin the magnets quite fast to get a result. If you can't see the light from the bulb, try testing the generator in a dark corner of the room. If this still doesn't work, you may need to use stronger magnets or coil more wire around the outside of the cardboard.

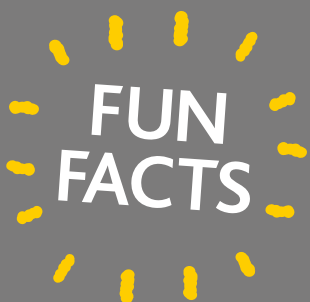

- 1 The first electrical generator was created by Michael Faraday in 1831
- 2 The fastest speed attained by a solar-powered vehicle is 91km/h by the Japanese Sky Ace TIGA, in 2014
- 3 In July 2016, Solar Impulse 2 became the first aeroplane to fly around the world powered totally by renewable energy. It spent 23 days in the air
- 4 If we could harness all of the energy from the sun, in one hour we could store enough energy to power the entire world for a whole year. However, right now we only have the technology to store a tiny amount of the energy given out by the sun

Future World

2 Does My Outfit Look Rubbish?

Objective

In this activity pupils will discover what materials our clothes are made from and how they could be recycled. Pupils will explore different materials for clothes.

TOPIC LINKS

- 🔗 Science: materials and their properties, recycling
- 🔗 Design and Technology: clothing design

ESSENTIAL SKILLS SUPPORTED

Listening, creativity, teamwork

TIME

🕒 60 minutes

RESOURCES AND PREPARATION

Selection of clothes made from different materials (cotton, nylon, Lycra, polyester etc.)

- selection of junk material
 - plastic, bubble wrap, plastic bottles, carrier bags etc
- sticky tape
- paper clips
- iPads or computers for research (optional)

HEALTH AND SAFETY:

A suitable risk assessment must be carried out by the activity leader and any significant findings recorded: if carried out in schools, guidance from CLEAPSS or SSERC must be used where appropriate.

Make the pupils aware of the risks associated with using plastic materials, including choking hazards and the dangers relating to sharp, hard plastic.

Pupils will need to use scissors while making their clothes, so ensure that they are properly supervised throughout this process and understand the need to act responsibly beforehand.

DELIVERY

- 1 Ask the pupils to think about where their clothes come from. How are they made? Are the materials natural or synthetic?

- Explain that it is important that we have an awareness of how certain products are made. Explain that today, lots of clothes are produced using machines. Many other clothes are made by people in countries such as China, India and Bangladesh. Many companies that make clothes now use synthetic materials, which are materials that cannot be found in nature and must instead be made by using chemicals. However, some clothes are still made only using natural materials. Allow the children some time to research the topics of natural and synthetic materials on their own in groups.

- 2 What happens to their clothes when they throw them away? Can any be recycled? Allow children time to research this on their own in groups.

- Most types of clothing – both synthetic and natural materials – can be recycled. However, clothes are commonly given to charity and reused instead of being recycled. It is very important that we either donate or recycle our old clothes instead of throwing them away.

- 3 Watch this video from BBC news www.bbc.co.uk/news/av/magazine-39864106/plastic-waste-turned-into-clothes-to-save-our-oceans about how waste plastic can be turned into clothes.

TIPS

- Try exploring a range of natural and synthetic materials.
- Make sure the waste plastic has been cleaned and that it is appropriate for being used in clothing i.e. nothing too heavy, nothing sharp.



- 4 Ask the pupils to design their own outfit from alternative materials, such as plastic bottles, bags and newspapers. They should explain what situations their outfit would be suited for, and why they chose the materials they did.
- 5 Allow time for the pupils, in groups, to make basic prototypes of their designed items of clothing. They should keep in mind the situations when their clothing would be useful and the environmental impact of using recycled plastics to make their clothes.
- 6 Have a mini fashion show where students can ask questions about other people's items of clothing. Encourage the children to evaluate their own design and think about how they might improve it.

EXTENSION IDEAS

- 1 Set up a spreadsheet to calculate the clothing miles in the average school uniform. Where was everything made, and how far has it had to travel to get to you?
- 2 Test and compare the properties of different synthetic and natural materials. For example, which is best for insulating – wool, cotton, polyester fleece, neoprene?
- 3 Pupils could find out about the invention of new materials such as neoprene, Gore-Tex and nylon, and explore how humans moved from natural to synthetic materials over time.
- 4 Find out about clothes recycling. How much of their wardrobe could be recycled and turned into new clothes?

DIFFERENTIATION IDEAS

Support: Provide some information about natural and synthetic materials, as well as information about global textile production, to help the students with their research.

Challenge: Ask pupils to include a description of why they want to use each material and why its properties are useful for the particular piece of clothing they are designing.

USEFUL LINKS



Video from BBC news about how waste plastic can be turned into clothes
www.bbc.co.uk/news/av/magazine-39864106/plastic-waste-turned-into-clothes-to-save-our-oceans

Future World

2 Does my outfit look rubbish?



Briefing



We throw away our own body weight in waste materials every two months. Could we put that waste to better use in the future? Perhaps we could turn it into clothes?

YOUR TASK Plan and design an outfit made entirely from waste plastic, card and paper.

WHAT YOU NEED TO DO

- 1 Find out what different clothes are made from. Which materials are synthetic and which are natural? What properties do the different materials have? What properties make a material better suited for certain types of clothing, but not others?
- 2 Find out what happens to clothes when they get thrown away. Can clothes be recycled? How many clothes get put into landfills or are disposed using other unsustainable methods of disposal, such as being burnt?
- 3 Collect a pile of (clean) waste plastic, such as, bags, yoghurt pots, bottles, milk cartons and anything else you think could be used to make clothes!
- 4 Design an outfit that uses these materials. Draw and label your outfit to show which materials you have used. Think about how certain materials could be useful for your outfit – for example, do they make the outfit more waterproof, warm, lightweight or durable?
- 5 Use the space below to design your outfit. Write down your ideas about the materials that should be used. When would someone want to wear this outfit?
- 6 After you've designed your item of clothing, make it! Make sure that you keep in mind when your item of clothing would be worn. Could it be used to keep you warm? Or dry?
- 7 Put on a mini fashion show for the rest of your class. Ask questions about other people's clothes and think about how you could change your item of clothing to make it better.

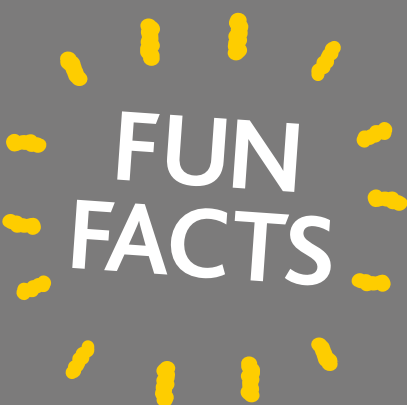

- 1 The first fully synthetic plastic was invented in 1907 by Leo Baekeland, in New York. He was experimenting with two chemicals: formaldehyde and phenol. He named this new plastic Bakelite.
- 2 No commonly used plastics are biodegradable. This means they do not rot away. It's thought that almost 8 million tonnes of plastic end up in the oceans every year, where it can be very dangerous to sea creatures. This is one reason why it is important to recycle our plastic waste!
- 3 The Great Pacific Garbage Patch can be found in the North Pacific Ocean between Hawaii and California. It covers an area roughly twice the size of France and contains around three million tons of discarded plastic rubbish. Similarly, massive plastic zones have been found in the Atlantic Ocean, the South Pacific Ocean and the Indian Ocean.

Future World

2 Does my outfit look rubbish?



Notes



CLUB LEADER GUIDE: SUITABLE FOR AGE 9-11

Future World

3 Future clothing

Objective

In this activity, pupils will explore and create wearable technology with lights and LEDs.

TOPIC LINKS

 Design and technology: design and make electronic clothing and wearable tech

ESSENTIAL SKILLS SUPPORTED

Presenting, creativity, aiming high

TIME

 60 minutes

RESOURCES AND PREPARATION

There are many different DIY wearable technology kits out there, some of which are more elaborate and expensive than others. For this activity, only a basic kit is required. Below is a link to a site where an affordable wearable technology kit can be bought.

Kitronik Electro Fashion - www.kitronik.co.uk/c2735-electro-fashion-sewable-light-kit-blue-flat-sewable-leds.html

If you want to buy the electronic equipment separately, rather than in a prepared kit, you will need:

- coin cell holders
- 3V coin cells
- conductive thread
- a variety of sew-on LEDs.

You'll also need

- old T-shirts, gloves or hats as a base for the electronics
- sewing needles
- scissors
- sew-on press studs (for switches)
- long nose pliers.

HEALTH AND SAFETY:

A suitable risk assessment must be carried out by the activity leader and any significant findings recorded: if carried out in schools, guidance from CLEAPSS or SSERC must be used where appropriate.

Be sure to inspect all the pupils' work to ensure that the items of clothing are safe to wear once the wearable technology has been attached. Look out for pieces of metal that could lead to electric shocks and any sharp protrusions that could break the skin.

DELIVERY

- 1 Show the pupils an article about LED clothes <http://mashable.com/2016/02/11/led-clothes>. Wouldn't it be great to have a shirt that could light up whenever you wanted, adding a whole new dimension to your clothing? What about a pair of gloves that lights up when you touch your fingers together, or a hat that has lights on it to help you stay visible at night?
- 2 Can the pupils brainstorm ideas for other ways that wearable technology could be used? Can they make their own designs that incorporate LEDs into pieces of old clothing, either adding aesthetic appeal to the item of clothing or using wearable technology to solve some problem?
- 3 Explain that they are going to explore wearable technology. Can they design an outfit that uses LED's, either to make the item of clothing look better or for some functional reason? Remind them to think about how the press studs should be used to make switches. Also remind them about the equipment that they have available – they should use the items of clothing in the classroom as a basis for their design.



TIPS

- For information about funding for your STEM club, refer to The STEM Clubs best practice handbook www.stem.org.uk/stem-clubs/support.
- The wearable technology you use in this activity should be limited to simple circuit technology – nothing which requires anything more than the component of a basic circuit. This should make it easier for you show the pupils how to create their clothing and easier for the children to understand how it works.
- Use the guide in the Useful Links section below to instruct you as to how the equipment should be used and to provide creative ideas about how to enhance clothing using simple circuits and wearable technology.
- As this activity includes sewing you may want to allow for extra time and ask a colleague to help!



- 4 After the students have designed their item of clothing, get them into groups and allow them time to share their ideas with other pupils. Encourage the pupils to provide feedback about how to improve their design. Should they use a different coloured LED, a more complex circuit, or sew on other pieces of material?
- 5 Give the pupils time to update their designs in-line with the suggestions made by their peers.
- 6 Using the wearable tech and the sewing equipment, have the children make a prototype of their item of clothing.
- 7 If there is time, hold a mini fashion show at the end of the class, so that everyone can show off their light-up clothing and wearable tech.

EXTENSION IDEAS

- 1 Pupils can incorporate other types of wearable technology into their outfit, for example sensors that detect sound and then relay a signal to the LEDs, which will then light up in sync with external sound.
- 2 They could include an LED matrix and code this so that their outfit can display a message.

DIFFERENTIATION IDEAS

Support: show the students how to make a simple circuit using the wearable technology that you have. They can then attach the circuit to an item of clothing in whatever way they like.

Challenge: Encourage those pupils who are particularly able to create complex circuits to create artistic wearable technology. Some students could even design matching hats/gloves, building on a particular theme or style that they create.

USEFUL LINKS



Kitronik's Guide to Sew-On Electronics

www.kitronik.co.uk/pdf/Electro_fashion_sewable_LED_kits_web.pdf



Future World

3 Future clothing

Briefing



Electronics such as microcontrollers and LEDs are becoming so small that it is now possible to sew them into clothes to produce electronic clothing! Your task is to explore some of these electrical components, design and then produce an outfit that can light up!

YOUR TASK Design and make an item of clothing that lights up!

WHAT YOU NEED TO DO

- 1 Explore the components that have been provided for you.
- 2 Design a light-up outfit that uses these components. Think about the circuit that you might use, the piece of clothing you will attach it to, and what effect you want the electronics to have. Draw your ideas in the space below.
- 3 Discuss your ideas with other people. Use their feedback to improve your design. Then, it is time to make it!
- 4 Test out the circuit you want to use before attaching it to an item of clothing. Once you know that your components work, attach them to your item of clothing using the conductive thread and press studs to complete the circuit.
- 5 Does your item of electronic clothing look like you hoped it would? If you were to do this again, what would you do differently? Look at what the other people in your club made to get ideas about how you could improve your item of wearable technology.

EXTRA

Design an item of wearable technology that you wish you could build, but maybe you don't have the scientific knowledge or budget to make it happen. Make sure that your item of clothing helps to solve a problem. Maybe it could be used to help cyclists be seen at night, or be used by elderly people to alert their family when they fall ill. Explain what it would do, and how it would work and who would find the technology useful.

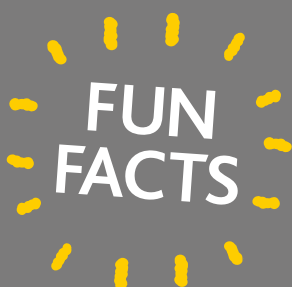

- 1 Some sports clothes manufacturers have already made clothes that include heart rate monitors that check your heart rate as you exercise
- 2 Scientists are researching a Smart Bra that can detect types of breast cancer
- 3 In the future, it's thought we could even be wearing smart patches directly on our skin, which could monitor our vital signs and even administer medicines as and when we need them

Future World

3 Future clothing



Notes

Future World

4 Drone pilot

HEALTH AND SAFETY:

A suitable risk assessment must be carried out by the activity leader and any significant findings recorded: if carried out in schools, guidance from CLEAPSS or SSERC must be used where appropriate. Pupils should take care when cutting or putting holes in their containers.

TIPS

- You may want to build, program and test a sample crumble drone to see what is achievable for your pupils in a 60-minute session and to fully understand the challenge.
- You can simplify the drone build by using the specially designed plug and play Crumble geared motors and wheels (see Option 1).
- You may find the drone easier to steer if you replace the front axle and wheels with a small ball caster, this will help the drone to turn.

Objective

In this activity, pupils will explore how some drones, such as space probes, are programmed to follow predetermined paths. Pupils will then set up their own drones to follow a programmed route.

TOPIC LINKS

- Computing: coding and algorithms
- Design and Technology

ESSENTIAL SKILLS SUPPORTED

Listening, aiming high, staying positive

TIME

60 minutes

RESOURCES AND PREPARATION

Required for either option:

- 1 Crumble controller
- 2 Crumble-friendly switches
- 1 Crumble friendly battery box (and 3xAA batteries)
- computers with crumble software
- 1 micro USB cable
- 6 crocodile clip leads
- 1 egg box, plastic takeaway box or similar
- 1 small ball caster (optional)
- 2 wheels (K'Nex or similar)
- K'Nex rods and connectors
- 1 axle (K'Nex rod or similar)
- glue gun, blu tack, sticky tape
- masking tape

Option 1

- Pair of Crumble geared motors with croc-leads
- Crumble wheels for geared motors

Option 2

- 2 DC motors
- 2 small motor shaft pulleys
- 2 small axles (K'Nex or similar)
- 2 wheels (K'Nex or similar)
- 2 pulleys (suitable for the axle)
- 2 small rubber bands

DELIVERY

We have provided two options for designing and building the drone. Option 1 uses Crumble plug and play. Option 2 challenges pupils to design their own solution.

1 Explain that many drones are remotely piloted, which means someone is controlling them via a remote control. Some drones, like self-driving cars, are even able to control themselves using artificial intelligence.

We've also sent drones into space. The Curiosity robot on Mars and the Rosetta and Philae probes that we sent to comet 67P are examples of drones. We can't pilot these directly because it takes too long for our radio signals to reach them.

These kinds of drones need to be programmed in advance. The engineers in charge of this, work out a set of instructions for the probes to carry out in order to achieve their goal. These drones often have very complicated goals, so the instructions programmed by the engineers needs to be very precise and accurate.

2 Set out a simple maze using masking tape on the floor. Pupils will assemble simple robotic vehicles using egg boxes, wheels and axel and will then programme crumble to drive two motors attached to both rear wheels of vehicle. Pupils will programme the motors and not just use crocodile leads to control the drone, however this is an option you could consider.

3 Pupils follow the instructions in the Pupil guide to build the body of their drone, program the Crumble, and attach all the elements. Pupils may need guidance on building the rear axles, attaching the wheels and connecting the motor.

4 Debug: if the drone goes wrong or can't navigate around the maze, pupils check the program, change it, and try again. They can also increase the speed in the coding blocks once they are comfortable operating the drone.

5 Discuss with pupils what results they observed. Besides missions to space, how could drones be useful in real life? What are some challenges people might have in designing and programming them?

EXTENSION IDEAS

1 Add and program sensors such as line detectors and lights. Make the maze more complex for the drones to navigate.

DIFFERENTIATION IDEAS

Support: give pupils the full set of instructions in the Pupil guide and allow them to follow along.

Challenge: give pupils the equipment and allow them to experiment on their own to get their Crumble set up.

USEFUL LINKS

- Basic instructions to build and program a steerable buggy <https://redfernelectronics.co.uk/crafty-crumble-creations-a-steerable-buggy/>
- More complex sensors and coding for Crumble <https://4tronix.co.uk/blog/?p=1004>
- CrumbleBot Links
Redfern Electronics - <https://redfernelectronics.co.uk/product/crumble-robotic-vehicle-full-kit/>
Mindsets Online - <https://mindsetsonline.co.uk/product-category/crumble/>
4Tronix - <https://shop.4tronix.co.uk/collections/kits>
- Code-It Crumble buggy
Lots of information on how to build and programme a buggy including different types of axles – <http://code-it.co.uk/cb>

Future World

4 Drone pilot



Briefing

Drones can now be set up to follow pre-programmed paths. In this activity, you are in charge of a space mission to Mars. You need to navigate your exploration drone from the landing site to the exploration zone.



WHAT YOU NEED TO DO

- 1 Select a box or carton to use as the body of the drone, or you could make your own. You need to put two axles through the body of your drone where the wheels will be attached. To do this, cut or poke two pairs of holes across from each other on the long ends of your container. Make sure the opening of the container is facing up. This is where the crumble controller and battery will sit. If you are using a ball caster instead of a front axle and wheels, simply attach it towards the front of the box in the center.



- 2 Think about how you will use the two motors to power the drone. Each motor should provide power to one of the rear wheels, as they need to work independently of each other. Your club leader will tell you which of the following solutions you will use:

- Option 1: Use a set of Crumble wheels, motors and attached crocodile clips. The wheels easily push on to the geared motors.
- Option 2: build your own split rear axle system. You will need: 2 wheels, 2 motors, 2 short axles, 2 motor shaft pulleys, 2 large pulleys, 2 small rubber bands and a way to support the axles. Each of the small axles will be powered by their own motor. Push the axle through the body of the drone and then attach the wheel. Support the axle inside the body so that it rotates but does not flap about. Slide a large pulley on to the axle and fix in place. Push the motor shaft pulley on to the motor and fix the motor in place so that the two pulleys line up. Place the rubber band over the two pulleys and connect the motor using the crocodile clips. You will need to do this for each side of the buggy. Use the diagram below to help you.

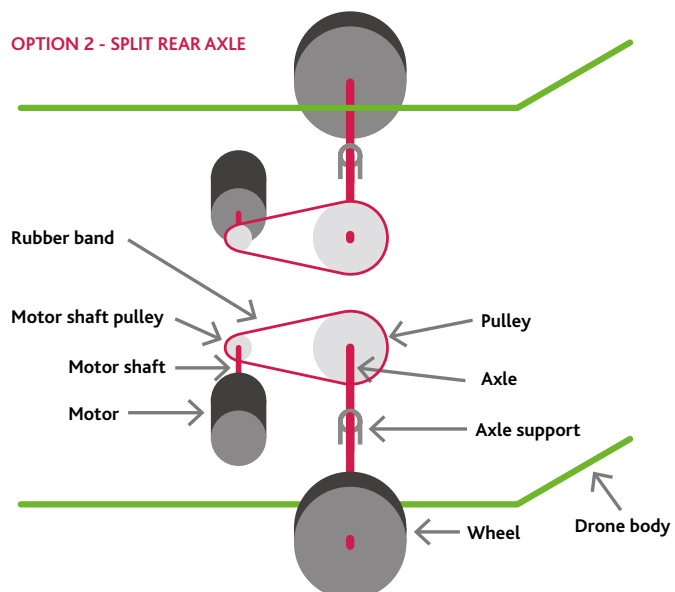

Future World

4 Drone pilot

- Connect the motors to the crumble board. You need them to move in opposite directions, so connect the crocodile clips as shown below:

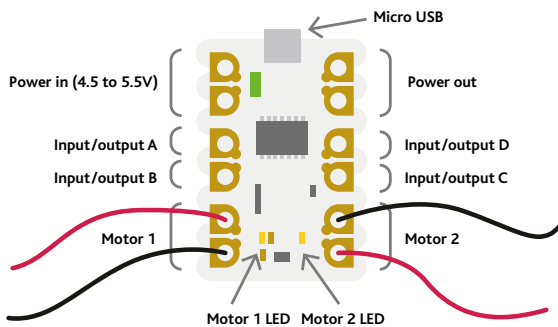

- Connect one switch for each motor: one should go between the second positive pad on the battery pack, and input/output A on the Crumble. (This is the yellow cable in the diagram below).

- The other should go between the 'Power Out +' and the Input/Output D pad on the Crumble. (These are the green cables in the diagram below.)

- Connect the battery pack with the other black and red cables as shown below.

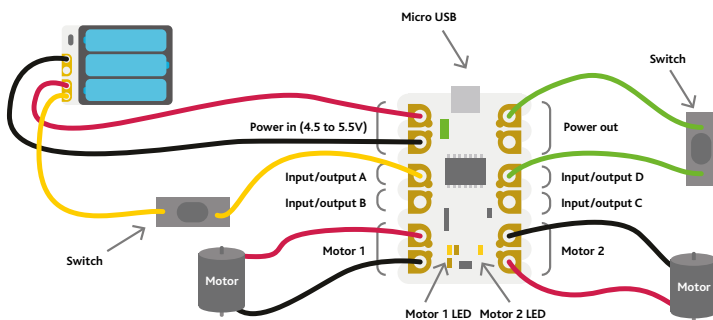

- Program the Crumble so you can safely navigate the path with your drone. Open the Crumble program and set up the code you need to make the drone navigate around the course.

Things to think about:

- Both motors need to operate in the same direction to move the drone forwards or backwards.
- How you will make the drone turn, which motor in which direction will turn the drone left or right?
- Think about the angles and distances needed to move the drone so it successfully navigates the course. Write them down to help you plan your program.

Example code - remember it will not move your drone around your course, but it will give you ideas of what to do.

Tip: if you press both switches ("A is Hi" and "D is Hi"), both motors activate and the drone will move forwards. If you only press one switch, only one of the motors will start and your drone will turn.

```

program start
do forever
if A is HI and D is HI then
motor 1 FORWARD at 25 %
motor 2 FORWARD at 25 %
else
if A is HI then
motor 1 FORWARD at 25 %
else
motor 1 STOP
if D is HI then
motor 2 FORWARD at 25 %
else
motor 2 STOP
end if
end if
end if
loop
    
```

- Download your program using a micro USB cable. Now it's time to test it out!
- Did your program work and did your drone complete the course? If not, check the program, change it and try again. Make notes of what works well and what could be better.
- Discuss with your club leader what results you observed. Besides missions to space, how could drones be useful in real life? What are some challenges people might have in designing and programming them?

FUN FACTS

- The Rosetta Space probe was sent to study a distant comet, known as comet 67P. It launched in 2004 and took over 10 years to get to the comet. By the end of its mission in 2016, it had travelled 6.4 billion km!
- Because Mars is so far away, it takes 13 minutes to get a message to the Curiosity Rover! NASA scientists use a simulator program to work out the instructions for the

next day which are then sent to Curiosity. At the end of the drive, Curiosity sends data back to Earth which is then used to work out the journey for the next day, and so on.

- In 1977 the space probes Voyager 1 and 2 were launched with a mission to explore the gas giant planets. They are still travelling today and in 2012 Voyager 1 actually left our solar system and is now in interstellar space!

CLUB LEADER GUIDE: SUITABLE FOR AGE 9-11

Future World

5 Sounds delicious

Objective

In this activity pupils will carry out an investigation to see whether certain frequencies of sound (measured in hertz) can affect our taste buds. Pupils will carry out an investigation into taste.

TOPIC LINKS

- Science: senses / sound
- Design and technology: cooking and nutrition

ESSENTIAL SKILLS SUPPORTED

Listening, leadership, teamwork

TIME

60 minutes

RESOURCES AND PREPARATION

- sound generator - apps are available for tablets such as signal generator or you could use an online signal generator such as www.szynalski.com/tone-generator/
- headphones
- paper cups
- water
- marker pens
- digital scales
- granulated sugar
- table salt
- plastic spoons
- cotton buds
- paper towels
- measuring cylinder
- pipettes

HEALTH AND SAFETY:

A suitable risk assessment must be carried out by the activity leader and any significant findings recorded: if carried out in schools, guidance from CLEAPSS or SSERC must be used where appropriate. Good hygiene must be adhered to when carrying out any taste testing.

Be very careful not to make any of the solutions, including the initial tasting solution, too salty. Salty water can make people very sick, so it is essential that none of the solutions being drunk exceed 1% salt. None of the salty solutions should be drunk in excess.

Make sure the volume is not too loud and that the pupils do not abuse the equipment.

Ensure that no students in the class have any problems drinking water containing sugar or salt before beginning the experiment.

DELIVERY

- 1 Ask the pupils if they can remember the main flavours that the tongue can detect. (Sweet, sour, salty, bitter and umami.)
- 2 Ask them if they can think of other things that affect the way we taste things, other than the taste buds on our tongues. Explain that we can taste many more flavours than just the five mentioned earlier, because our sense of smell detects chemicals in our food and adds to the flavour of the food we eat.
- 3 But does our hearing get involved too? Some studies suggest that changing the sounds we hear while we eat can affect what foods taste like. Some top chefs have begun providing headphones with their food, with music carefully chosen to enhance the flavour. Is this actually something we can test?
- 4 Studies have shown that high frequency sounds, or sounds with a high pitch, can enhance the sweetness of foods, whereas low frequency sounds, or sounds with a low pitch, can make foods taste more bitter. While you should explain to the students that you know the expected results of this experiment, do not tell them what the expected results are. Explain that telling them the expected results could alter the way they record their results, which would mean that the test wasn't fair.



TIPS

- Be prepared for this not having any effect at all!
- Make sure the pupils have an understanding of the tastes of salt and sweet before you begin the test. Have the students try an obviously salty solution and obviously sugary solution so that they have a baseline to work from.
- To help you measure small amounts (1ml etc) try using a medicine syringe without a needle!

(There are also studies that claim to have shown that low-frequency sounds also bring out umami flavours.)

- 5 Explain to the pupils that they are going to carry out an investigation to see if there's any truth to the claims that sound frequencies can affect the way we taste foods. After they have prepared the equipment, get the students to create a bitterness/sweetness scale which can be used as a standard measure for all their different results. Explain that this will make it easier to compare all the results and make a final judgement on whether sound did affect the way the pupils tasted.

Get them to rate the flavours and observe the results. If this works, how could it be used in the real world?

EXTENSION IDEAS

- 1 Try eating different flavours of crisps – ready salted, salt and vinegar, etc. Ask people to rate how good they taste when listening to the sound of the sea, and when not listening to anything. Is there any effect?
- 2 Try tasting different flavours of crisp with the nose held shut. How does this affect the flavour? Is it easy to tell the difference between different flavours in a blind taste test?

DIFFERENTIATION IDEAS

Support: preselect the different sound frequencies that will be used and prepare the salt and sugar solutions in advance. The pupils can focus on listening to the sounds, tasting the solutions and recording their results.

Challenge: have the pupils determine the sound frequencies they should listen to, the number of solutions they should test and the concentration of each of the solutions. Have them justify their choices before allowing them to start experimenting.

USEFUL LINKS

- 🔗 Online tone generator
www.szynalski.com/tone-generator/
- 🔗 BBC article about a chef who uses music to enhance the taste of a dish
<http://news.bbc.co.uk/1/hi/england/berkshire/6562519.stm>

Future World

5 Sounds delicious

Briefing

We know too much sugar isn't good for us, but it's hard to resist! But what if we could use sound to help us tame our sweet tooth? One study suggests that changing the sounds we hear while we eat can affect how foods taste. Is this true?

YOUR TASK Set up an experiment where people listen to different music or sounds while eating. Does it affect how sweet the food tastes?

WHAT YOU NEED TO DO

- 1 Measure out 100ml of water. Add 10g sugar and stir it until it has dissolved.
- 2 Label this cup 10% sugar.
- 3 Take 1ml of water from this cup and put in a new cup. Add 9ml of fresh water. Label this cup 1% sugar.
- 4 Repeat this to make a 0.1% and 0.01% sugar cups, and label them.
- 5 Ask your taste subject to rinse their mouth with plain water and wipe their tongue clean.
- 6 Ask them to dip the cotton swab into the 10% sugar solution and rub it on their tongue. Can they taste the sugar?
- 7 Repeat with the different sugar solutions. Be sure to clean their mouth each time.
- 8 Record how sweet each of the solutions taste on a scale, with 0 being not sweet at all and 10 being extremely sweet. Be sure to carefully mark on this scale how sweet each of the solutions are.
- 9 What is the lowest concentration at which they can taste sweetness?
- 10 Put the headphones on, and play a 100hz tone (deep tone).
- 11 While keeping the headphones on, repeat the experiment. Does this change their ability to taste sugar?
- 12 Once again, record how sweet each of the solutions taste on a scale of 0 to 10.
- 13 Repeat with a higher pitch tone, such as 3000hz.
- 14 Once again, record how sweet each of the solutions taste on a scale of 0 to 10.
- 15 What are your findings? Does the sound have any effect on how we taste things?
- 16 If this works, how could it be used in the real world? Do you think in the future we might listen to music when we eat in restaurants? Might we use sounds instead of seasonings in the future? We all know how bad salt and sugar can be for our bodies. Do you think people might use sounds as a healthier option to salt and sugar?

FUN FACTS

- 1 The chef Heston Blumenthal created a fish dish called Sounds of the Sea. The meal comes with headphones and an MP3 player with the sound of crashing waves playing. His studies show that these sounds make the food taste stronger and saltier.
- 2 In an experiment, people were asked to wear headphones whilst eating crisps. Sometimes they heard a much louder crunch, and other times a more muffled one. However, the crisps themselves never changed. From this study, it was found that a louder crunch made people think the crisps were fresher and tastier than when they heard a muffled thud.

Future World

5 Sounds delicious



% of sugar	Sounds heard while tasting	How sweet did it taste? (0-10)

Conclusion

You could repeat this with salt solutions (to see how sounds affect salty tastes), coffee (to see how sounds affect bitter tastes) and vinegar solutions (to see how sounds affect sour tastes) too, if there's time.

Safety: don't play the sounds too loud! Reduce the volume to prevent hearing damage.

CLUB LEADER GUIDE: SUITABLE FOR AGE 9-11

Future World

6 Grasshopper burger anyone?

Objective

In this activity pupils will carry out a survey to see what people think about some of the possible things we might be eating in the future. Pupils will carry out a survey to explore our opinions on different futuristic foods.

TOPIC LINKS

- 🔗 Maths: data handling
- 🔗 Science: healthy eating
- 🔗 Computing: spreadsheets

ESSENTIAL SKILLS SUPPORTED

Listening, presenting, problem solving

TIME

- 🕒 30 minutes set up / 30 mins analysis

RESOURCES AND PREPARATION

- computer
- word processor
- spreadsheet software
- examples of insect products (optional, but highly recommended)

HEALTH AND SAFETY:

A suitable risk assessment must be carried out by the activity leader and any significant findings recorded: if carried out in schools, guidance from CLEAPSS or SSERC must be used where appropriate.

Insect products are already available online and in stores. It is highly recommended that you bring in some examples of insect products to show the pupils to make the topic more accessible. However, it is not recommended to allow pupils to taste them, unless you have explicit permission from parents. The allergy risks of these products have not been fully explored to date.

DELIVERY

- 1 Does anyone fancy a grasshopper burger? Or maybe a maggot curry? Did you know that insects are very high in protein? It's thought that in the future we may be relying a lot more on insects for food.
- 2 It's very energy-intensive to farm large animals like cows and pigs, and potentially much easier to farm insects such as grasshoppers. As the population of the world keeps increasing, maybe we'll all have to switch to insects instead!
- 3 How about not eating a whole insect, but grinding them into flour to bake bread?
- 4 Ask the group what they think of this. Is eating a grasshopper any different to eating a prawn?
- 5 Tell the pupils that they are going to carry out a survey to see what other people think about this possible future for food. If they want to use the results of their survey to inform a menu of insect meals, what kind of questions should they ask?
- 6 When they have the results of their survey, ask them to put their data into suitable graphs and charts (e.g. pie charts and bar graphs will probably be the most appropriate).
- 7 Ask the children to use the graphs and charts to inform an insect menu that they are going to create. They want to design meals that people would want to eat, despite including insect products. For example, if people said that they would be more likely to eat insects if they were ground up, maybe have a dish that uses insect flour rather than whole insects.



TIPS

Suggested questions might include:

- if you knew a burger was made from insects, would you eat it? (Yes/no/maybe)
- would you consider eating something made from insects if you couldn't see the insect
- what type of insect products would you be willing to try? (Whole insects, insect chocolate bars, insect biscuits, insects flour, insect stew, none)
- why would or wouldn't you eat an insect? (open question)
- possible insects to ask about include mealworms, crickets/grasshoppers, ants, locusts, caterpillars and cockroaches, as these are the most likely candidates for future insect foods.

EXTENSION IDEAS



- 1 Have pupils research some of the different food options out there. Some countries already eat insects. Can they find out about the different ways insects are already eaten?
- 2 Pupils create an advertising campaign to promote insects as a new food source. They should come up with a catchy slogan or jingle, and could film a short commercial, or record a radio advert.

DIFFERENTIATION IDEAS

Support: some pupils might need scaffolding to produce their survey, and some help in structuring some questions. They might need assistance collating the results.

Challenge: pupils could create an online survey in something such as Google Forms. This could be sent out to parents to fill in to create a larger set of data to explore.

USEFUL LINKS

-  [Guardian article about making bread from cricket flour \(Finland\)](http://www.theguardian.com/world/2017/nov/23/anyone-for-crickets-bread-made-insect-finnish-bakery-fazer)
-  [BBC Future story exploring whether insects are the future of food](http://www.bbc.com/future/story/20140603-are-maggots-the-future-of-food)
-  [Telegraph article about the UK's first bug restaurant](http://www.telegraph.co.uk/news/earth/agriculture/food/11952931/Bug-burgers-and-cricket-crepes-Britains-first-insect-restaurant-opens-in-Wales.html)
-  [How to overcome your phobia of eating insects](https://www.eatcrickster.com/blog/fear-of-insects)

Future World



6 Grasshopper burger anyone?

Briefing



Farm animals like cows and pigs need a lot of space, food and water. Some people think that as the population of the world increases, we'll need to start looking at more efficient ways to get our food. They think we would be better off eating insects. But are we ready for that?

YOUR TASK Plan and carry out a survey to find out what people think about eating insects, then use your findings to make a menu of insect meals that you think people would eat!

WHAT YOU NEED TO DO

- 1 Think of some questions that you'd like to ask people about eating insects. Have people already eaten insects, perhaps on holiday? What kinds of thing have they eaten/would they eat? If they won't eat an insect, what reasons might there be? Would they be more likely to eat some insects over others? You need to use questions that will help you to make a menu of insect meals that people would want to eat!
- 2 Set up your survey using the table below. Ask your survey questions to people in your school/club and fill in your table. Once you have filled in the survey, write up your conclusions in the space provided. (You could also set one up online in order to ask more people.)
- 3 Draw graphs to present your data. Use pie charts and bar charts as appropriate.
- 4 When you have your results in easy-to-understand graphs and charts, use your results to make an insect food menu that you think people would eat! The food needs to be delicious, but only contain insects and a few other ingredients.

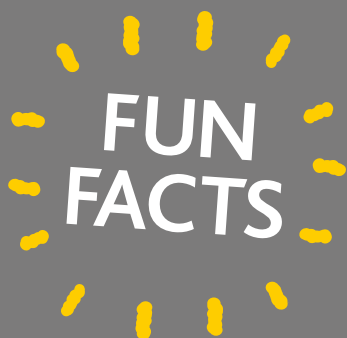

- 1 There are over 900,000 different species of insect on Earth. It's thought that about 1900 species would be suitable for humans to eat
- 2 It's thought that there are about 10 quintillion insects on Earth - that's 1 with 18 zeros! That means that there are 2 million insects for every human alive today
- 3 Insects are very high in protein. 1 kg of termites provides approximately 350g of protein whilst 1kg of beef contains 320g of protein
- 4 Insects emit 60 times less methane gas compared to cows. Methane gas has 25 times more of an impact on global temperature levels than carbon dioxide, so switching to insects could help slow down climate change

Future World

6 Grasshopper burger anyone?



Question	Answer One	Answer Two	Answer Three	Answer Four

Conclusions

CLUB LEADER GUIDE: SUITABLE FOR AGE 9-11

Future World

7 Through the keyhole



HEALTH AND SAFETY:

A suitable risk assessment must be carried out by the activity leader and any significant findings recorded: if carried out in schools, guidance from CLEAPSS or SSERC must be used where appropriate.

Objective

In this activity pupils will find out about how modern surgeons carry out operations without opening the patient up, and explore how robots are changing surgery. Pupils will simulate keyhole surgery.

TOPIC LINKS

-  Science: keeping healthy
-  Computing: use of technology











ESSENTIAL SKILLS SUPPORTED

Listening, problem solving, staying positive

TIME

 45 minutes

RESOURCES AND PREPARATION

-  matchboxes
-  plastic tweezers
-  metal tweezers
-  satsumas
-  small pieces of pasta
-  mini whiteboards
-  webcams + laptops
-  string
-  modelling clay
-  stopwatch

DELIVERY

- 1 Ask the pupils if anyone has ever had an operation. Was there a big scar? Explain that when surgeries were carried out 100 years ago, even something minor would require a large hole to be cut so the surgeon could access the correct area.
- 2 Explain that nowadays, it's possible to carry out quite major surgery without needing to cut a person open – instead, surgeons can just make a small incision in their patient's body. This modern type of surgery uses a tiny camera with a light attached to it, which can be put inside the body through a small hole. The camera sends a video image to a screen in the operating room, allowing the surgeons to see inside their patient's body without having to open them up with a large incision. Using special tools, the surgeon can then operate on their patient's organs only using this screen to see what they are doing. This type of surgery is called Laparoscopy or keyhole surgery.
- 3 How easy would it be to operate on a person when you can only see what you are doing on a screen? We're going to find out.

Note: Look at the pupil guide to get a full sense of how this activity works.
- 4 Demonstrate how to set up the equipment. Use a webcam connected to a laptop – this will give you the video feed from which the students need to navigate their 'surgery'. Show how to put some small items into a matchbox with tweezers. Put a screen in place so that the pupils cannot see what they're doing other than by using the screen, then try again.
- 5 Then tell the pupils it's their turn to try.
- 6 Using webcams and laptops, each group can carry out the challenges with the screen in place to see how easy it is.



TIPS

-  You could also use a visualiser and project onto an interactive whiteboard.



EXTENSION IDEAS

Make a fake joint for 'surgery': take two balls of modelling clay – these are the two muscle-covered bones that make up the most significant part of the knee joint. Stick two short lengths of drinking straw to the top – these represent where the ligaments that hold the bones together should go. Add some short lengths of string across the clay, press them in at one end, but keep the other ends free – these are the torn knee ligaments. Cover this in a thin foam sheet – which represents the skin. (In reality, the ligaments don't go through tubes like this, but it's an extra level of challenge.)

To operate on the 'knee', peel back the foam, thread the pieces of string through the straws, then put the foam back in place.

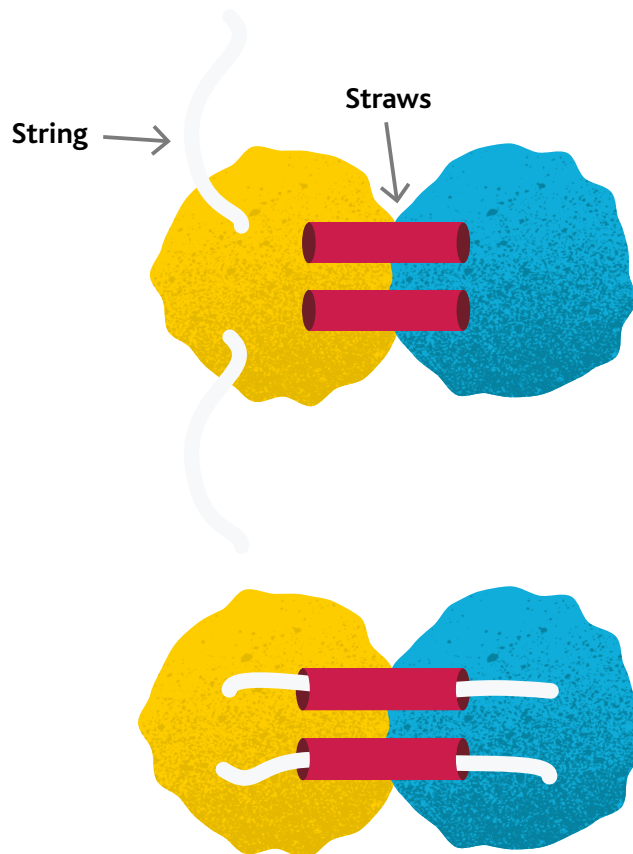



DIFFERENTIATION IDEAS

Support: pupils can assemble a small puzzle or another less delicate task.

Challenge: pupils can operate on a pretend "knee" joint using the keyhole surgery set up. Prepare a pretend knee joint which needs some ligaments reattaching.

USEFUL LINKS

-  [BBC story about a doctor who operates from over 400km away](http://www.bbc.com/future/story/20140516-i-operate-on-people-400km-away)
www.bbc.com/future/story/20140516-i-operate-on-people-400km-away
-  [NHS information about laparoscopy](http://www.nhs.uk/conditions/laparoscopy/)
www.nhs.uk/conditions/laparoscopy/
-  [YouTube video showing a robot performing surgery on a grape!](https://youtu.be/KNHgeykDXFw)
<https://youtu.be/KNHgeykDXFw>



Future World

7 Through the keyhole

Briefing



For years, surgeons often had to cut people open in order to perform surgery on them. If this wasn't an option and a surgeon was unable to make a big enough incision to operate on, for example, someone's knee, they would often just cut off the whole leg! Today, surgeons often carry out surgery inside the body without cutting the patient open. Instead, they cut a small hole in the skin, poke a tiny camera and a torch through the hole and use the camera to see what's going on. This is called keyhole surgery and it is a much safer method for performing surgery.

Do you think you could perform complicated tasks without directly being able to see what you're doing? Well, today we're going to find out!

YOUR TASK Carry out a simulation of keyhole surgery.

WHAT YOU NEED TO DO

- 1 Use plastic tweezers to put small pieces of pasta into a matchbox. Then take them out again. Time how long it takes you to put all the pieces in the match box and take them out again, recording your results in the table below.
- 2 Place a screen between you and the matchbox, so you cannot look directly at your hands. Set up a webcam to project the image of the matchbox onto a laptop screen. Repeat the task again and record your results in the table.
- 3 Try some other tasks, such as peeling a satsuma with a pair of tweezers in each hand, tying shoelaces or threading cotton onto a needle. Do you find it easier to use the video feed now that you're getting used to not looking at your hands?

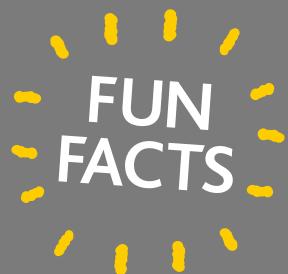

- 1 In 2001 the first operation using a remote robot surgeon was carried out. The surgeon was in New York and the patient was in France!
- 2 Using artificial intelligence, some robots are now being developed which can carry out an operation without a surgeon being present. Operations have been carried out on animals such as pigs, with use on humans still a few years away.

Future World

7 Through the keyhole



Name	Time without Screen	Time with Screen

4 Can you think of any other ways to make these tasks easier? Would certain tools make the tasks easier? What if two people worked together to complete the tasks? Try making your own tool that can be used during the surgery. Record your ideas below, and test them out.

Change made	Effect

CLUB LEADER GUIDE: SUITABLE FOR AGE 9-11

Future World

8 Electrical dough

Objective

In this activity, pupils explore how to create conductive dough. They will discover how making changes to the ingredients changes how conductive their dough can be.

TOPIC LINKS

- Science: investigating different circuits. Looking at conductors and insulators.

ESSENTIAL SKILLS SUPPORTED

Listening, presenting, problem solving

TIME

60 minutes

RESOURCES AND PREPARATION

- plain flour
- water
- cooking salt
- granulated sugar
- brown sugar
- deionised water
- food colouring (various)
- cooking oil
- digital scales
- 1.5v x aa battery packs
- different coloured led lights
- plastic bowls
- wires
- crocodile clips
- other electrical devices such as small buzzers and motors.
- ammeter / multimeter

HEALTH AND SAFETY:

A suitable risk assessment must be carried out by the activity leader and any significant findings recorded: if carried out in schools, guidance from CLEAPSS or SSERC must be used where appropriate.

LEDs can be dangerous. Do not connect them directly to a battery. Be careful with the metal legs as these can scratch. Do not swallow.

Do not drink the deionised water or eat the conductive putty. Ensure that the dough is not stored for long periods or it will become contaminated with microorganisms such as moulds. If stored, keep in fridge or freezer as you would fresh food. Handling by multiple people can be a source of contamination, so ensure hands are washed properly and dried after handling the dough.

CONDUCTIVE DOUGH RECIPE

- 130g cooking salt
- 195g plain flour
- 350cm³ of tap water
- two tablespoons of cooking oil
- a few drops of food colouring (optional – but will help to tell the difference between the different doughs)

Mix the salt and flour in a large bowl. Add the cooking oil. Gradually add the water and keep mixing until you get a sticky dough-like texture. Take the dough out of the bowl and knead it with your fingers. You might not need to add all the water.

Optional extra. Add a teaspoon of lemon juice to see if this has any effect.

Make different versions of this dough with different amounts of salt – 50g, 130g and 180g and see what difference it makes.

INSULATING DOUGH RECIPE

- 130g granulated sugar
- 195g plain flour
- 350cm³ of deionised water
- two tablespoons of cooking oil
- a few drops of food colouring

Mix the sugar and flour in a large bowl. Add the cooking oil. Gradually add the water and keep mixing until you get a sticky dough-like texture. Take the dough out of the bowl and knead it with your fingers. You might not need to add all the water.

Try brown and white sugar and see if there are any differences.



DELIVERY

- 1 Ask the children to think about conductors and insulators. What kind of materials are usually conductors? What kind of materials are usually insulators? Do they think it's possible for something that's not a metal, such as dough, to be a conductor?
- 2 Demonstrate with a ready-made batch of conductive dough. Take one lump of dough. Insert the battery pack wires into the dough and insert an LED. Does the LED light up? They should find that this does not work, as there isn't a proper circuit.

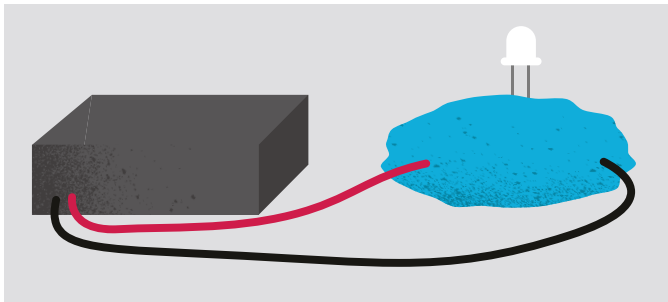

- 3 Now separate the conductive dough into two pieces. Make sure the two pieces are not touching. Plug one wire from the battery pack into each piece of wire. Bridge the gap with an LED. Does the LED light up now?

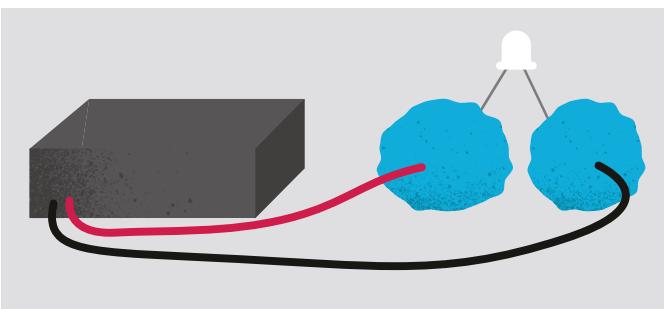

- 4 Take the LED out, flip it around and put it back into the dough so that each leg is now in the other piece of dough. Does it light now?
- 5 Roll the dough into long thin tubes. Show that circuits do not have to be neat and straight to work. You can bend playdough into all kinds of shapes; it's still a conductor.
- 6 Ask the pupils to try different recipes for dough to see which ingredients make the best conductor. Allow them time to play with and explore each type of dough to see if it conducts or not. Change the amount of salt in the recipe to see what difference it makes.
- 7 Ask them to create and fill in a table to show their findings. Draw the circuits that they make.
- 8 Does using more or less dough affect the results? Connect up a buzzer using thin wires of dough. How loud is the buzzer? Make the dough thicker and see if this has any effect on the sound of the buzzer. Is there a difference between long circuits made of dough or shorter ones?
- 9 Once the pupils have identified which dough is the best conductor, and the best insulator allow the pupils' time to explore and create different circuits with the dough. Use several LEDs as well as buzzers and motors.

CLUB LEADER GUIDE: SUITABLE FOR AGE 9-11

Future World

8 Electrical dough

CONNECTING UP LEDs

LED is short for Light Emitting Diode. Diodes only conduct electricity in one direction. Unlike a regular light bulb they need to be connected up so that electricity flows through them the correct way.

Look closely at the LED. One leg will be longer than the other. The long leg will need to be on the side of the circuit closest to the positive (or red) terminal of the battery pack.

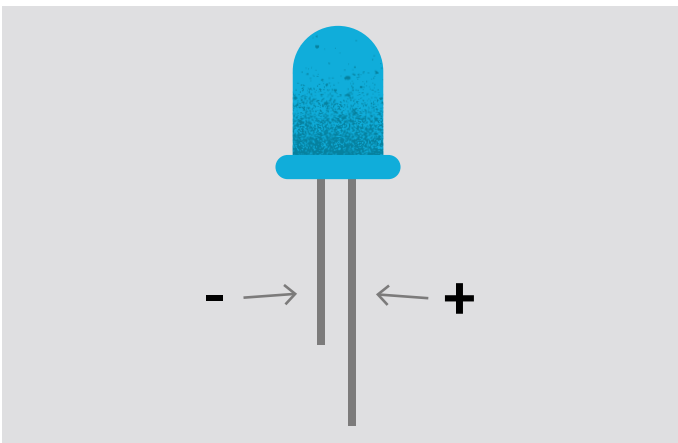

WHAT'S GOING ON?

For a material to be conductive, it needs to be able to allow electricity to move through it. When the salt is mixed with the water in the dough, it splits into charged ions of sodium and chloride. These charged ions allow the electric current to move freely through the material.

Granulated sugar does not split into ions when it dissolves. Dough made with sugar will not conduct. For the best insulator, also use deionised (distilled) water as it has no other dissolved ions in it.

TIPS

- Use a different colour for each dough they create to make it easier to tell the difference between each one. Plus, it makes their circuits look better!
- For best results, use a battery pack with 4 x 1.5V AA batteries.
- Make a sandwich by placing a layer of insulating dough inbetween two layers of conductive dough. This lets the pupils create interesting shapes in their circuits that do not need to be kept apart.

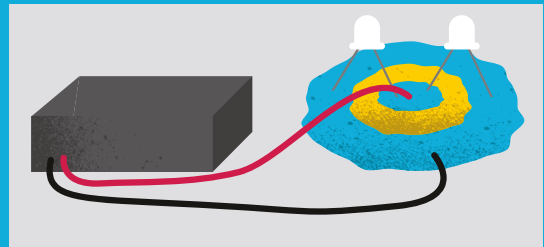

You could even make a conductive hamburger! Like this:

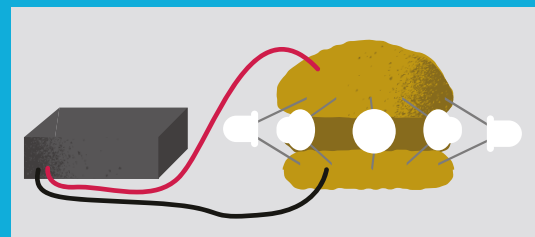

EXTENSION IDEAS

- 1 Connect up the conducting playdough to a Makey Makey. Use it to build a game controller to control a character in a game written in Scratch.
- 2 You could also take this further and investigate commercially available conductive ink to literally draw electrical circuits on paper.

DIFFERENTIATION IDEAS

Support: pupils receive guidance on how to make the doughs. They could make two versions of conducting dough – one with salt and one without. Guide them on how much dough to use in the experiment.

Challenge: pupils design and test both series and parallel circuits and explore the differences between the two. Try to design the most creative shape for their circuits.

Future World

8 Electrical dough



Briefing



Electrical circuits are usually made from metal such as copper because it is such a good conductor. But how about trying something else? Could you really build a circuit out of something like dough?

YOUR TASK Your task today is to explore how to make the best conductive dough. Using some household ingredients, could you make a circuit using dough that makes an LED light up? What's the best conductor you can make?

THINGS TO THINK ABOUT

- 1 How can you make a good conductive dough? Try different amounts of salt in your dough to see what works best.
- 2 Can you make an insulating dough instead? Use sugar instead of salt and see what happens.
- 3 Can you build circuits using layers of both conductive and insulating dough? What type of shapes can you create? Is there a limit to the number of LEDs you can light up?

TIPS

- You can try using different amounts of salt to see which works best.
- Take some time to try out different shapes of circuit!
- Connect up your LED the correct way. Remember the longer leg is the positive (a plus is longer than a minus!)

FUN FACTS

- 1 The first visible LED was invented in 1962 by Professor Nick Holonyak who then worked for General Electric
- 2 LEDs use much less electricity than a traditional light bulb, because of this a lot of street lights are now using LEDs to save energy
- 3 LEDs can also be arranged in grids to make giant screens. One of the biggest in the world is the Suzhou Sky Screen in China. The screen is 500m long and 32m wide and has approximately 20 million LED bulbs
- 4 Water helps the conduction of electricity, a wet human body conducts electricity. That's why there are no light switches in the bathroom – except, for pull cords, which isolate the device

Future World

8 Electrical dough



RESULTS

Amount of salt in your dough	Describe how conductive this dough was.	Any other observations

REPORT

Look at your chart and tell the rest of the group what you've found out. Compare your results – which was the most conductive dough?

Future World

9 The Skills Builder Framework



The Activities and Employability Skills

Each activity within this resource pack has identified the essential employability skills it supports and develops in students. These skills have been mapped to the essential skills identified by the Skills Builder Framework, which breaks down eight essential skills into 16 teachable and measurable steps. Club leaders and teachers can use the activities to promote good practice and enhance each student's individual learning curve. Helping to promote transferable skills key to their education and future employment.

ABOUT THE SKILLS BUILDER PARTNERSHIP

The Skills Builder Partnership brings together educators, employers and skills-building organisations around a common approach to building eight essential skills. Their programmes include training and resources, supporting schools and colleges to embed a rigorous approach to building skills and achieve the Gatsby Benchmarks. As an individual teacher or Club leader, you can freely access a suite of online teaching tools and resources, designed by their team of teachers to build essential skills. The suite includes learning activities, supporting videos, classroom resources, assessment tools and the Skills Builder Framework, which you can use in STEM clubs and classroom teaching.

THE SKILLS BUILDER FRAMEWORK

The Skills Builder Framework breaks down eight essential skills into 16 teachable and measurable steps, providing a common set of expectations and a roadmap for progression. Step 0 is for the least experienced learners and Step 15 represents a highly skilled adult. The Framework can be used by teachers and Club leaders to talk to students about their skill strengths and areas for development and is a useful tool for framing conversations about careers and employability. Focusing student learning through the Framework, enables students to recognise their own essential skill levels and work to master them over time. The Framework can provide a language for students to articulate this progress to helping to develop employability skills and prepare students for future careers.

Skills Builder also provide multiple online assessment tools, including a student self-assessment, student-by-student teacher assessment and class-level formative assessment through the Skills Builder Hub. This means that programmes can be differentiated and focused to meet individual needs.

Future World

9 The Skills Builder Framework



EIGHT ESSENTIAL SKILLS

The eight essential skills broadly break down into four domains we know both teachers and employers value.

Communication

- 1 Listening – ability to listen and understand information
- 2 Presenting – vocal communication of information or ideas

Creative Problem solving

- 3 Problem Solving – ability to find a solution to a complex situation or challenge
- 4 Creativity – use of imagination and the generation of new ideas

Self-Management

- 5 Staying Positive – ability to use tactics to overcome setbacks and achieve goals
- 6 Aiming High – ability to set clear, tangible goals and devise a robust route to achieving them

Inter-personal

- 7 Leadership – supporting, encouraging and motivating others to achieve a shared goal
- 8 Teamwork – working cooperatively with others towards achieving a shared goal

You can find out more about essential skills and the Framework on the Skills Builder website, <https://www.skillsbuilder.org/framework> and you can access resources on the Skills Builder Hub <https://www.skillsbuilder.org/hub>

You can find additional support and information on careers and employability skills on the STEM Learning Careers pages, <https://www.stem.org.uk/stem-careers>. You can also download the free Skills Builder toolkit from the STEM Learning website <https://www.stem.org.uk/rxfum6>



Notes

Ruled lines for notes

Notes

Dotted lines for writing notes.

STEM Clubs Programme, led by STEM Learning

Achieving world-leading STEM education
for all young people across the UK.

For more information on the
programmes and publications
available from STEM Learning,
visit our website www.stem.org.uk