

LAUNCHING!

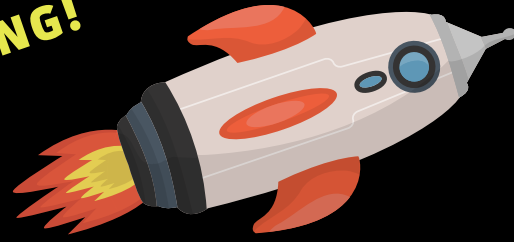

MISSION TO THE MOON

A STEM-BASED RESOURCE FOR PUPILS 5 TO 11

This collection of practical activities, investigations and games, encouraging pupils aged 5 to 11 to work scientifically, is based upon current lunar research and real data.

LOOKING!

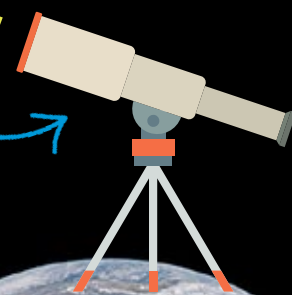

LANDING!

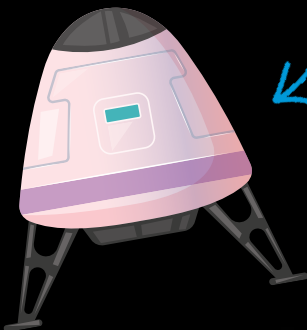

LIVING AND EXPLORING!

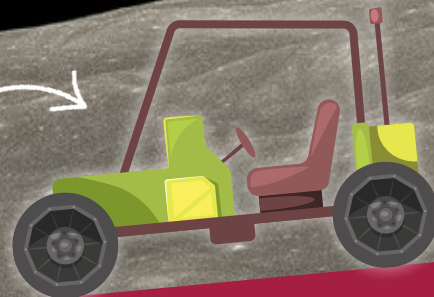



MISSION TO THE
MOON

A STEM-BASED RESOURCE FOR PUPILS 5 TO 11

Mission to the Moon

A STEM-based resource for pupils 5 to 11

ESERO would like to thank the following
for their help in developing this resource:

Sue Andrews – Author

Professor Andy Newsam – Liverpool John Moores University

Tom Lyons – Teacher Fellow, ESERO-UK

Rachel Jackson – National STEM Centre

Cliff Porter – Science consultant

Hannah Sargeant – Geologist

The Moon has been a source of fascination and wonder throughout history, preserving not only a unique record of the geological evolution of a terrestrial planet but also providing evidence of early impact bombardment of the inner solar system and the solar and galactic environment over the last 4.5 billion years. By studying the Moon, we can learn about the processes that have shaped the history of our Earth. Perhaps humans may colonise the Moon, setting up an initial group of scientists, engineers and technicians, to be joined by families and later expand into entire villages? Scientists believe that the Moon's potential resources could be used as valuable raw materials for the building of satellites, or for generating cleaner, safer, nuclear energy for use on Earth; water trapped as ice on the lunar poles might one day be used as rocket fuel!

This collection of practical activities, investigations and games, encouraging pupils aged 5 to 11 to work scientifically, is based upon current lunar research and real data. Teachers may choose to use the activities in any order, or as a series of challenges for a class, year group or whole school. Each has clear curricular and career links, involving science, technology, engineering or maths, and allows many opportunities for problem-solving, critical thinking, creativity and for enriching other areas of the curriculum.



Contents/Summary of Activities

SECTION	ACTIVITY TITLE	Activities AGES 5 to 7, AGES 7 to 9, AGES 9 to 11	CURRICULUM LINKS
Looking	1. Highlands and Lowlands	Observing lunar features using detailed images of the Moon Moon jigsaws Mountains and shadows investigation	Earth and space Data handling Measures Scale Light and shadow
	2. Looking for Landing Sites	Game using coordinates	Maths: using coordinates
Launching	3. Lift Off!	Air-powered rockets Measuring distance versus angle of launch Catapult launchers	Forces, friction, gravity Measures
Landing	4. Gently Does It!	Design a soft landing for a lunar craft	Forces, gravity Materials Design technology
Living and Exploring	5. Rolling Along	Lunar rover design	Design technology
	6. Water, Water, Anywhere?	Porosity Testing for pure water Melting ice	Rocks and soils Change of state

SECTION	ACTIVITY TITLE	Activities AGES 5 to 7, AGES 7 to 9, AGES 9 to 11	CURRICULUM LINKS
	7. Moon Dust	Make a Moon landscape Handling box for lunar rocks Investigating powdery materials Reducing particle size Drop tests	Changing materials Materials Forces
	8. The Power of Attraction – A Sticky Question	Static electricity	Comparing materials
	9. Crystal Mountains	Crystal growing	Changes of state, dissolving, evaporation, measures
	10. Digging the Dirt – Mining on the Moon	Mapping and sampling the lunar surface	Interpreting data Measures Rocks and soils Design technology, choosing tools, comparing materials
	11. Building Bricks	Investigating recipes for making bricks Strength tests	Rocks and soils Materials Forces Measures
Appendices	1. Role badges 2. Biographies 3. Book list 4. Quizzes	Links to careers Astronomer & lunar geologist Stories/poems with lunar links Moon trivia quiz	

Contents/Curriculum Links

ACTIVITIES	ENGLAND	NI	SCOTLAND	WALES
1. Highlands & Lowlands	Earth and space Data handling Measures Scale Light and shadow	Movement and energy Light and shadows Change over time: shadows Place in the universe Measures/number	Forces, electricity & waves: light and shadows Space: models of solar system	Enquiry How things work/light
2. Landing Sites Game	Information technology Coordinates	ICT: Explore, research/access information	Digital literacy: Explore & use ICT to research information & support learning	ICT Skills/ range-find and select information
3. Lift Off!	Forces, friction, gravity Measures	Movement and energy: Forces, pushes, pulls, surfaces	Forces: air resistance, friction, improving efficiency	How things work/forces Sustainable Earth/materials
4. Landing: Gently Does It!	Forces, gravity Materials Design technology	Movement and energy: design and make models	Materials: exploring properties Forces: investigating forces	How things work/forces Sustainable Earth/materials
5. Rolling Along	Forces, friction Design technology	Movement and energy: design and make models	Energy sources & sustainability: toys/energy Forces: friction/motion	Enquiry How things work/forces Sustainable Earth/materials
6. Water, Water, Anywhere?	Rocks and soils Change of state/reversible change	Change over time: change of state	Planet Earth: water changing form Properties & uses of substances	Enquiry/exploring Sustainable Earth/materials

ACTIVITIES	ENGLAND	NI	SCOTLAND	WALES
7. Moon Dust	Changing materials Materials Forces	Change over time: materials	Forces/effects Materials/change	Enquiry/exploring Sustainable Earth/materials
8. The Power of Attraction – A Sticky Question	Forces Properties & changes of materials	Movement and energy: forces/how things move	Forces: Investigating electrostatic forces	How things work/forces Sustainable Earth/materials
9. Crystal Mountains	Changes of state, dissolving, evaporation, measures	Place: changes in state Change over time: changes in everyday substances; dissolving, evaporating	Materials: exploring, dissolving, changes, separating	Enquiry skills How things work/forces Sustainable Earth/materials
10. Digging the Dirt! Mining on the Moon	Interpreting data Measures Rocks and soils Design technology, choosing tools, comparing materials	Place: origins/uses of materials Managing information: choosing tools/developing manipulative skills	Materials: separating Earth's materials: exploring/comparing	Enquiry skills Sustainable Earth/materials
11. Building Bricks	Rocks and soils Materials Forces Measures	Movement and energy: forces Place: use of materials Change over time: uses/properties/changing materials	Earth's materials: uses Forces: effect of forces Properties of materials	Enquiry skills How things work/forces Sustainable Earth/materials

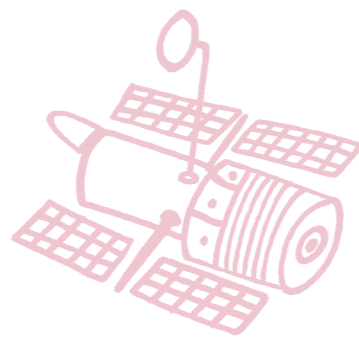

LOOKING

1 Highlands and Lowlands

The surface of the Moon is very different from that of Earth. Its surface has highlands and lowlands, mountains and craters. These craters are often marked by secondary craters caused by the impacts of asteroids and meteorites and by patterns called rays caused by ejected matter from these impacts. The dark regions on the Moon are called 'maria' or seas that are sites of meteoric strikes in lunar history; they later became lava-filled basins that filled with molten lava seeping up from the interior.

In this activity, the children take on the role of **astronomers** and use light sources to represent the Sun and plasticine to build mountains on a lunar surface. They learn that light from the Sun is blocked by mountains on the lunar surface producing shadows. They investigate how changing the angle of the light source and the size of the mountains affects the size of the shadows produced. They learn that astronomers can use maths to determine the height of the mountains on the Moon if they know the length of their shadow and angle of the sunlight.

★ ADVANCE PREPARATION

All classroom sessions involve the children working in groups of four. A set of role badges for 'astronomer' (found in Appendix 1) should be prepared before the lesson if the teacher wishes to use them. Print and prepare Moon images and jigsaws.

★ PLENARY ACTIVITY

Using the whiteboard, show the children several detailed images of the Moon. Ask the children to describe what they can see. Identify the maria or seas, craters, highlands and lowlands. Using the printed images provided on Activity sheets 1a, 1c, 1e, the children observe and identify key features. Images of individual features can be found on Activity sheet 1g.

A virtual tour of the Moon in 4K resolution by LRO-NASA can be enjoyed by following <https://moon.nasa.gov/resources/168/tour-of-the-moon-4k/>. Pause at 2.13 in the video to show the central mountain in the Tycho crater; this central uplift is formed during the impact of an asteroid with the surface.

★ PLENARY ACTIVITY

Explain that the Moon receives light from the Sun and, just as we do here on Earth, it experiences day and night. As it spins on its axis, only the part facing the Sun is illuminated whilst the rest remains dark. We on planet Earth can only see the part of the Moon that is illuminated. Use a torch and sphere, such as a large ball, to demonstrate night and day on the Moon.

Next, ask the children to look closely at the lunar images showing areas of the Moon experiencing daytime. *Can they identify these areas? Why are they light? Can they spot any dark features in these daylight regions? Can they explain why these areas might be dark when this half of the Moon is in sunlight?*



Explain that the children will be using the plasticine provided to build lunar mountains. They will use their torches to model the light from the Sun and investigate what happens when light is directed onto their mountains. The activity may be adapted to suit the age and abilities of the class. Younger children may simply try the activity, observe and compare, whilst more able children can plan their investigations, make careful observations, measure using standard measures and record data. Finally, they will look for patterns and draw conclusions, suggesting how their investigations could be improved next time.

★ GROUP ACTIVITY

Ages 5 to 7: Freely investigate building 'mountains' of various heights and observe the shadows produced. Use a sheet of paper or tray to act as the lunar surface.

Ages 7 to 9: Investigate changing the height of the plasticine 'mountains' and measuring the length of the shadows produced.

What must they keep the same each time? What will they change? What will they observe or measure? What do they think will happen and why? What do their results show?

Challenge the children to predict where they think the shadows will be if they change the heights of the mountains or the position of the torch.

Ages 9 to 11: The children investigate questions generated in their groups. They plan the investigation and control variables. They could consider the effect on the size of the shadow of changing the position of the torch (ie changing the angle of sunlight reaching the mountains). They could devise a method for ensuring the torch is held in the same position, distance or height each time. The groups use the data to plot line graphs showing length of shadow versus height of mountain.



★ **PLENARY ACTIVITY**

The children report their findings. Gather results from the groups and discuss the data with the class.

What happened when they shone the light from the torches onto the mountains? Can they explain this? Do they see any link between the height of the mountain and the length of the shadow? What happened when they changed the position of the torch and consequently the light falling on the mountain?

Read about Professor Andy Newsam, who is an astronomer (see Appendix 2).

EXTENSION FOR AGES 7 TO 9

The children look at the drawings on Activity sheet 1h. They draw the shadows of appropriate length and direction, according to the height of the mountains shown. Using Activity sheet 1i, they make plasticine mountains to produce shadows to match lengths of those shown.

EXTENSION FOR AGES 9 TO 11

★ **ADVANCE PREPARATION**

Print out the lunar images on Activity sheets 1a to 1f as large as possible.

★ **ACTIVITY**

Using the Moon maps on Activity sheets 1a to 1f, label one or two craters and provide the heights of the crater walls and/or the central mountain shown on Activity sheet 1j. Ask the children to measure the shadows for the crater walls using a ruler. The larger the printed image, the easier this will be. From that, they can calculate a scale for that image, eg if they measure a shadow of 6mm and the wall is 3km, the scale is 1km

tall for every 2mm of shadow. Then, they can measure other shadows and using their scale, calculate the heights of crater rims or mountains. You could point out a few for them to try, where you have the answer, or just leave them free to explore. Any answer between 0.5km and 6km will probably be correct!

What do they notice? What conclusions can they draw?

★ **BACKGROUND INFORMATION**

Galileo Galilei was the first person to show that the Moon was not a smooth sphere but imperfect, covered by craters and mountains. By drawing the Moon's surface at different times in the month when the angle of illumination would be different, he showed that changes in the light and shadow could be explained by the features on the lunar surface. He went on to calculate the height of lunar mountains by using their shadows. His calculations were quite accurate. Today, astronomers know that the best time to observe the Moon is during the first quarter, or the first few days past the new Moon. At this time, although less of its surface is illuminated, the Sun's rays strike the surface at a shallower angle, creating shadows and enhancing the physical features. When the Moon is fully lit, it is so bright that its physical features become 'washed out' and astronomers using telescopes would be dazzled.

If they know the angle of illumination of an object and the length of its shadow, astronomers can calculate the height of an object. However, they also need to make an adjustment for the position of the object relative to the centre line of the Moon. This centre line is the imaginary line where the Sun's rays hit the lunar surface at right angles. They then use algebra to obtain the final height.

Activity Sheet 1a ★ Lunar surface 1 in daylight

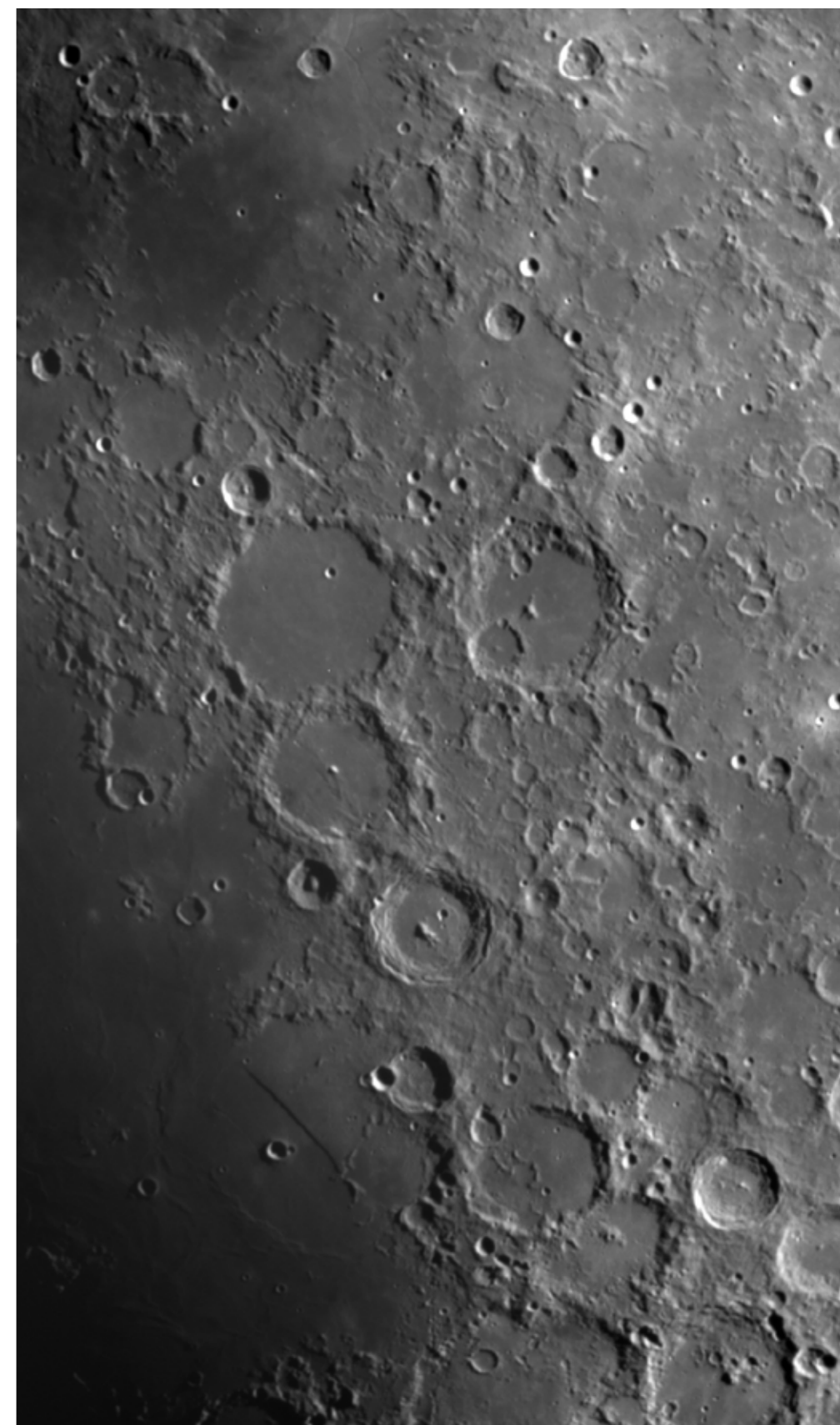

Activity Sheet 1b ★ Lunar surface 1 in daylight with labels

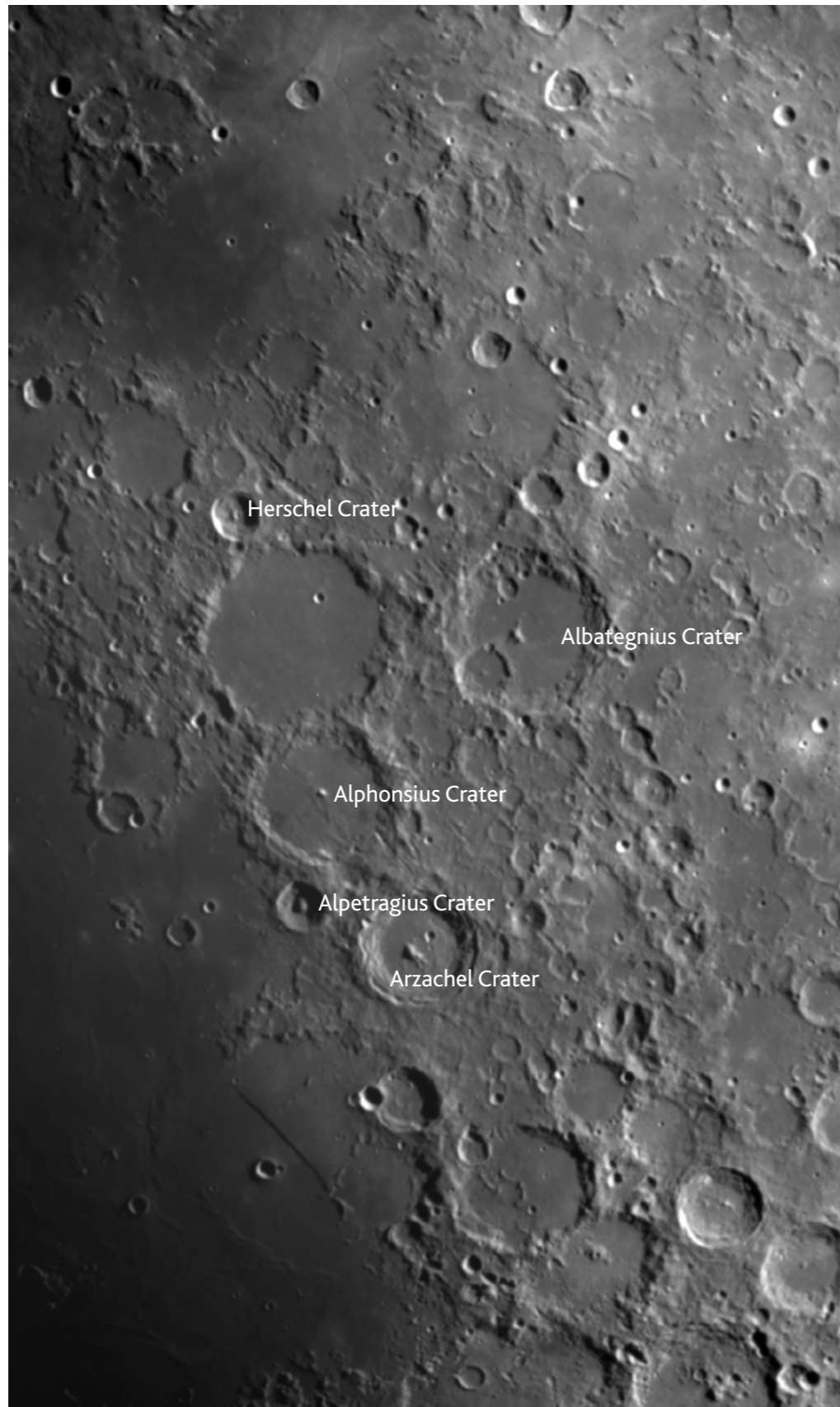

Activity Sheet 1c ★ Lunar image 2 without labels

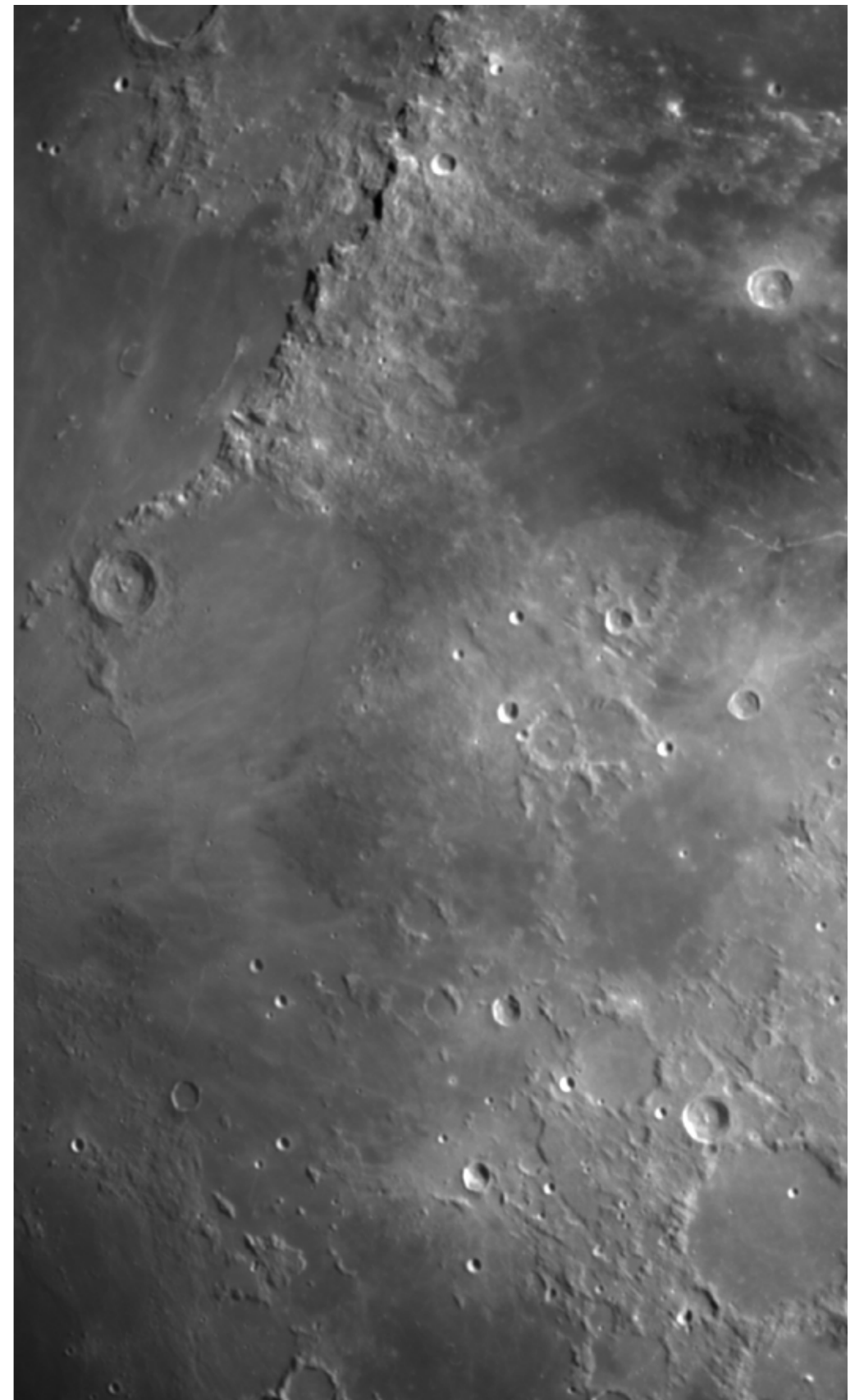

Activity Sheet 1d ★ Lunar image 2 with labels

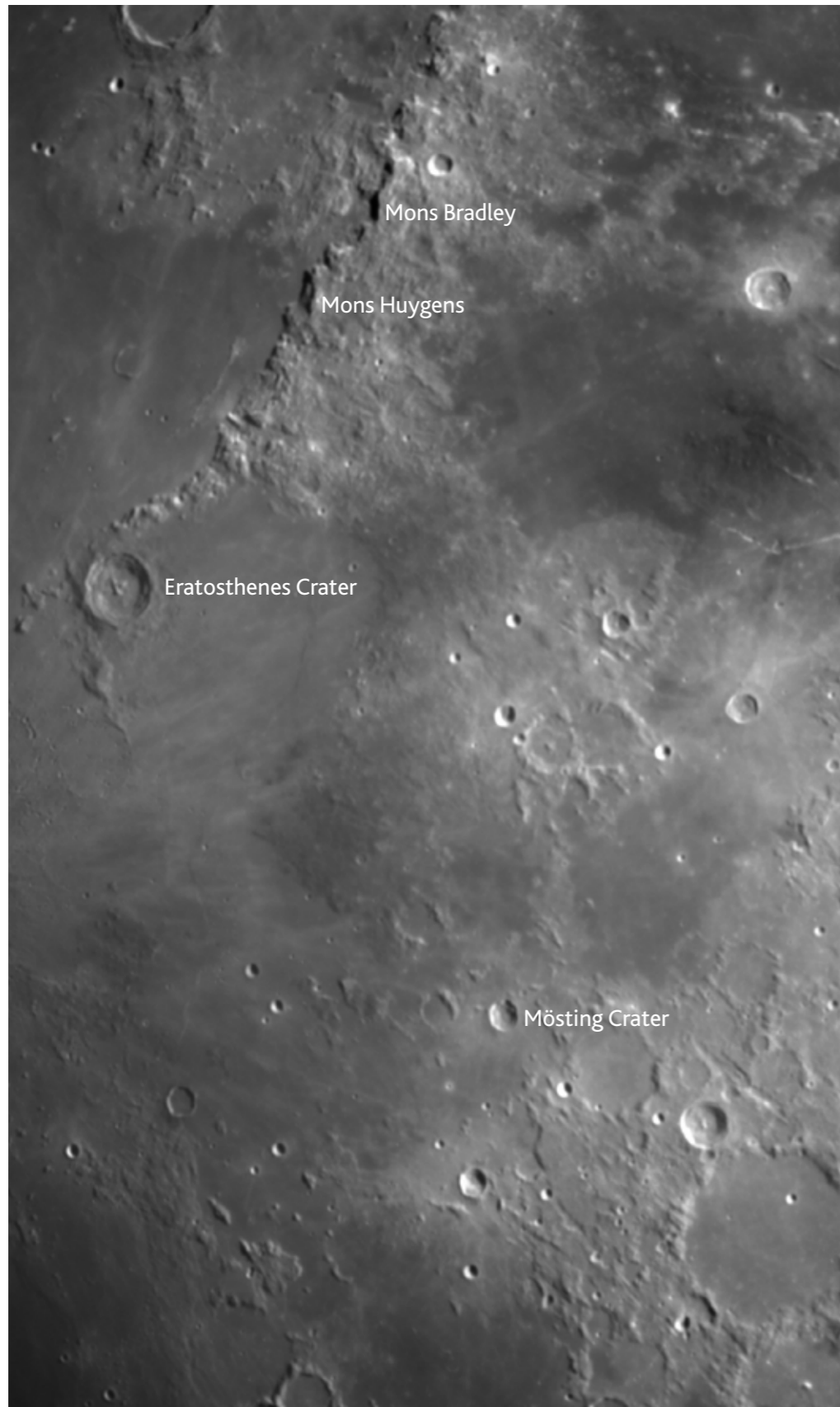

Activity Sheet 1e ★ Lunar image 3 without labels



Activity Sheet 1f ★ Lunar image 3 with labels

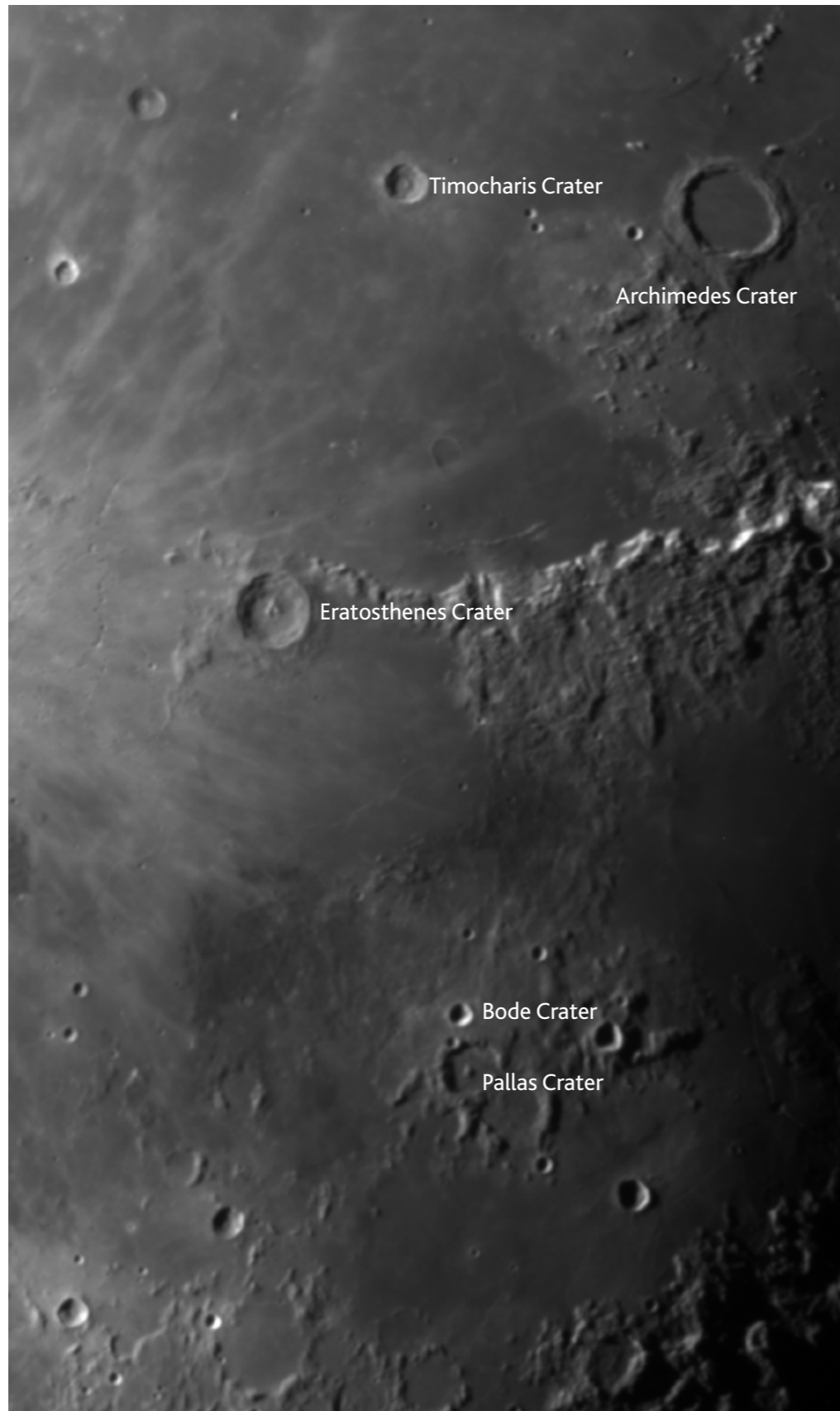

Activity Sheet 1g



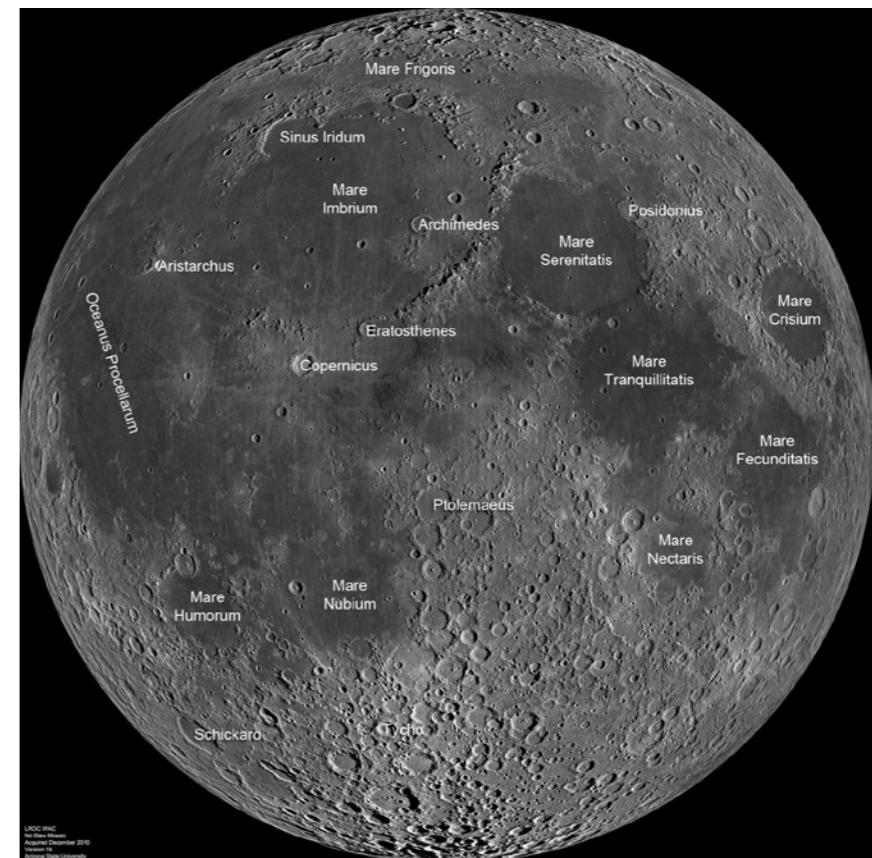

Craters

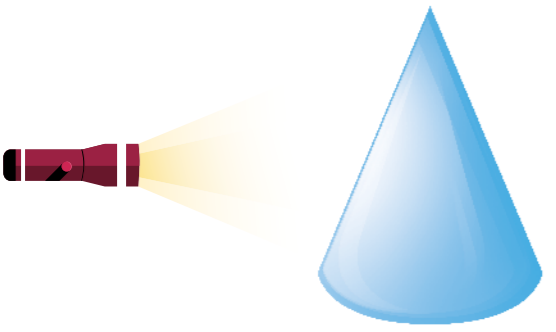
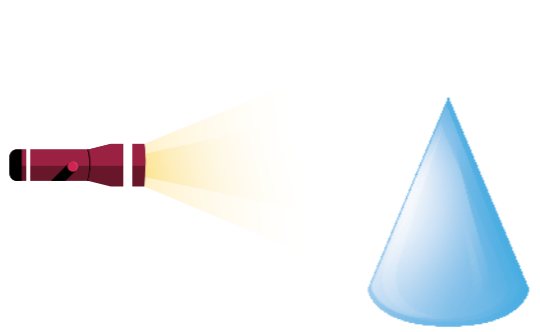
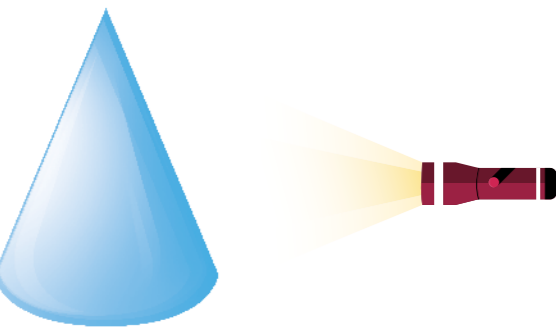
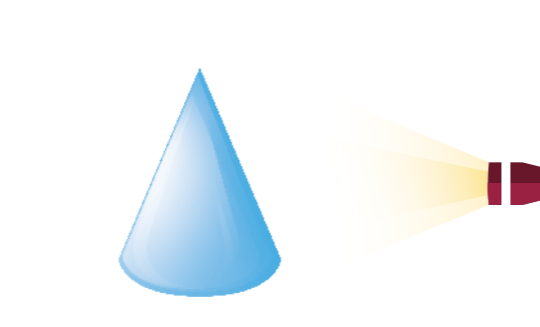
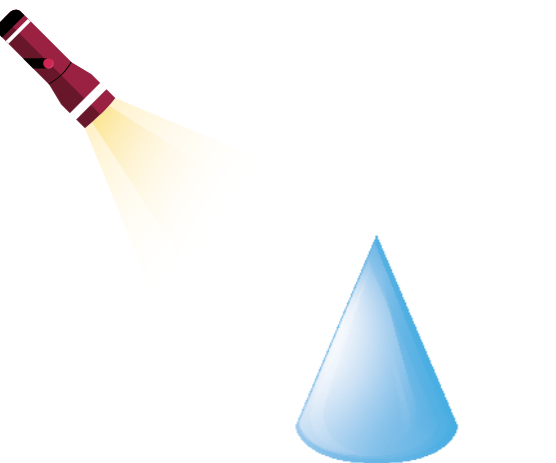

'Mare' means sea

Activity Sheet 1h ★ Draw the shadows

 <p>1</p>	 <p>2</p>
 <p>3</p>	 <p>4</p>
 <p>5</p>	 <p>6</p>

Activity Sheet 1i ★ Build the mountains to match the shadows

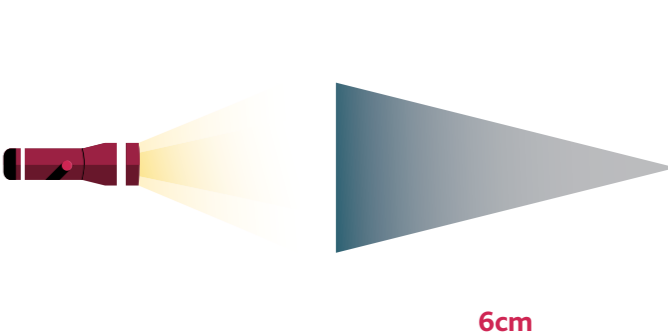
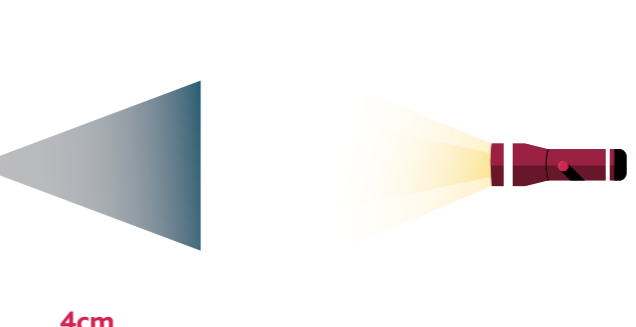
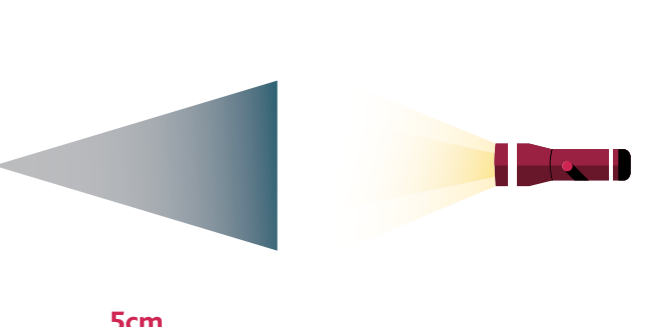
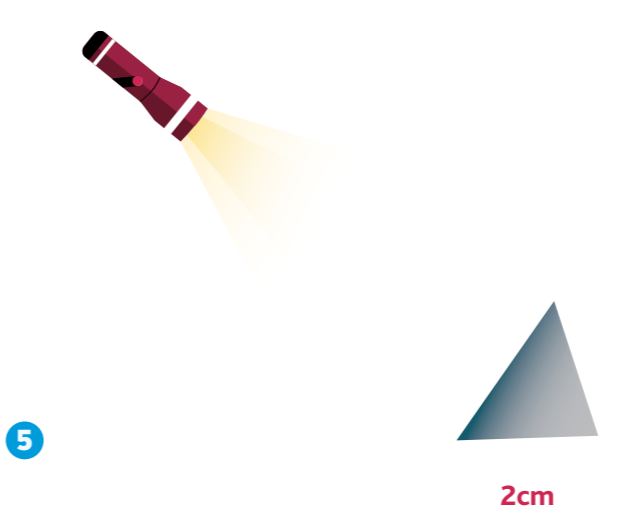
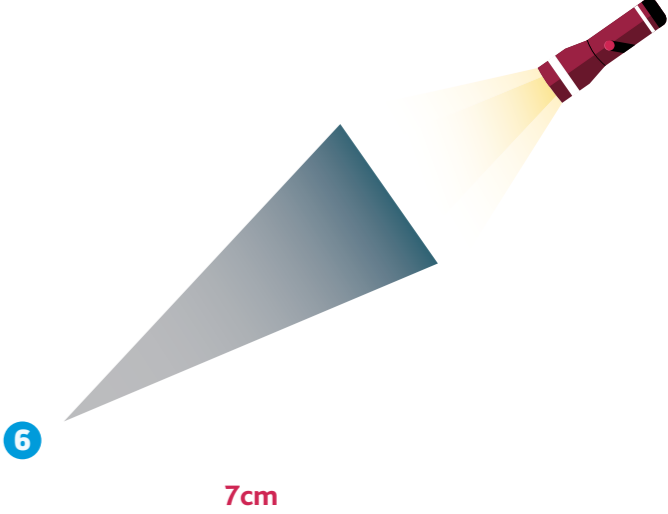
 <p>1</p>	 <p>2</p>
 <p>3</p>	 <p>4</p>
 <p>5</p>	 <p>6</p>

Activity Sheet 1j

DATA FOR CRATER RIM AND CENTRAL MOUNTAIN HEIGHTS (WHERE KNOWN) PLUS MAJOR MOUNTAIN HEIGHTS.

Crater name	Rim height	Central mountain height
Albategnius crater	3.2km	1.7km
Alpetragius crater	3.9km	2.0km
Alphonsus crater		2.0km
Archimedes crater	1.6km	
Arzachel crater	3.6km	2.0km
Bode crater	3.5km	
Eratosthenes crater	3.4km	Up to 1.2km
Herschel crater	3.3km	0.8km
Mösting crater	2.8km	
Pallas crater	1.3km	
Timocharis crater	3.0km	

Mountain	Height
Mons Bradley	Peak 4.2km
Mons Huygens	Peak 5.4km

LOOKING 2 Finding a Landing Site

Choosing a suitable landing site on the lunar surface is extremely complex. First, the topography and texture of the lunar surface must be considered. The lunar module needs specific conditions for its guidance and navigation systems to work and finally, the elevation of the Sun, the temperature of the surface and radiation levels must all be exactly right. Technological developments enable scientists to map the lunar surface in great detail. NASA's LRO – Lunar Reconnaissance Orbiter – can zoom in on features of the lunar landscape, dipping as low as 31 miles above the surface, providing images of incredible clarity.

In this activity, the children use computers to walk in astronauts' footsteps and zoom in to explore several landing sites of the Apollo programme. They consider the difficulties successful lunar missions face and the reasons why particular landing sites are chosen. Finally, they play a game using coordinates and a lunar map to locate possible landing sites on the Moon.

★ ADVANCE PREPARATION

Lunar maps enlarged, printed and ideally laminated or inserted in clear plastic file pocket

Attach the maps to the inside lids of pizza boxes to provide each group with two identical maps, one with labels and one without

Use of iPads or laptops

OBJECTIVES

- ★ Consider factors involved in choosing lunar landing sites
- ★ Become familiar with physical features of the lunar surface
- ★ Use coordinates to locate features on a lunar map

RESOURCES PER GROUP OF FOUR

- ★ Pizza boxes x 2
- ★ Lunar map with landing sites labelled x 1
- ★ Lunar map without labels x 1
- ★ Laptop or iPad x 2



★ **INTRODUCTION**

Introduce the lesson by showing the large map of the lunar surface and ask the children to identify key features such as ridges, craters, hills and seas.

<http://www.skyandtelescope.com/observing/how-to-see-all-six-apollo-moon-landing-sites/>

What would scientists and engineers need to consider when choosing a suitable landing site? What dangers might they encounter? What would the astronauts be looking for when they land? What samples would they want to collect?

Show each landing site for the Apollo missions 11, 12, 14, 15 and 17 using the Sky and Telescope link above. By scrolling down through the article, the children can then explore each landing site independently. Clicking on the images increases the resolution to enable the children to walk in the footsteps of the astronauts! Another useful link for exploring the Apollo landing sites is 'Google the moon':

<https://www.google.com/moon/>

An exciting interactive experience which recreates the Apollo 11 Moon landing in real time can be found at: <http://wechoosethemoon.org/>

Finally, groups of four can play the game 'Find the landing sites', based on the popular board game, Battleship. The children open the pizza boxes, with their lids vertical, shielding the maps from the opposite pair. One pair of children will have a labelled lunar map, showing the landing sites and coordinates (Activity sheet 2a). Their opposing pair will have a map with just coordinates shown (Activity sheet 2b). This pair guesses a square by choosing the horizontal followed by the vertical coordinate. If correct, each pair marks an 'x' on the square. They continue until they have found all the landing sites.

As an extension to this, two maps without marked landing sites could be used. One pair of players could choose and mark the landing sites on their map, whilst the other pair guesses the locations.



APOLLO 15



APOLLO 12



APOLLO 14

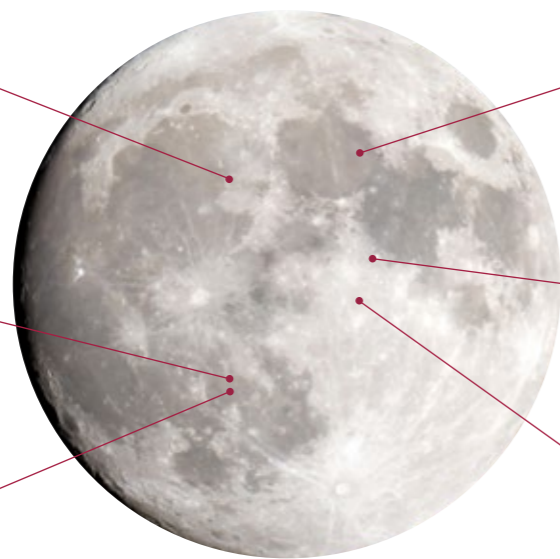

APOLLO 17



APOLLO 11



APOLLO 16

Activity Sheet 2a ★ Play the landing site game (Battleship)

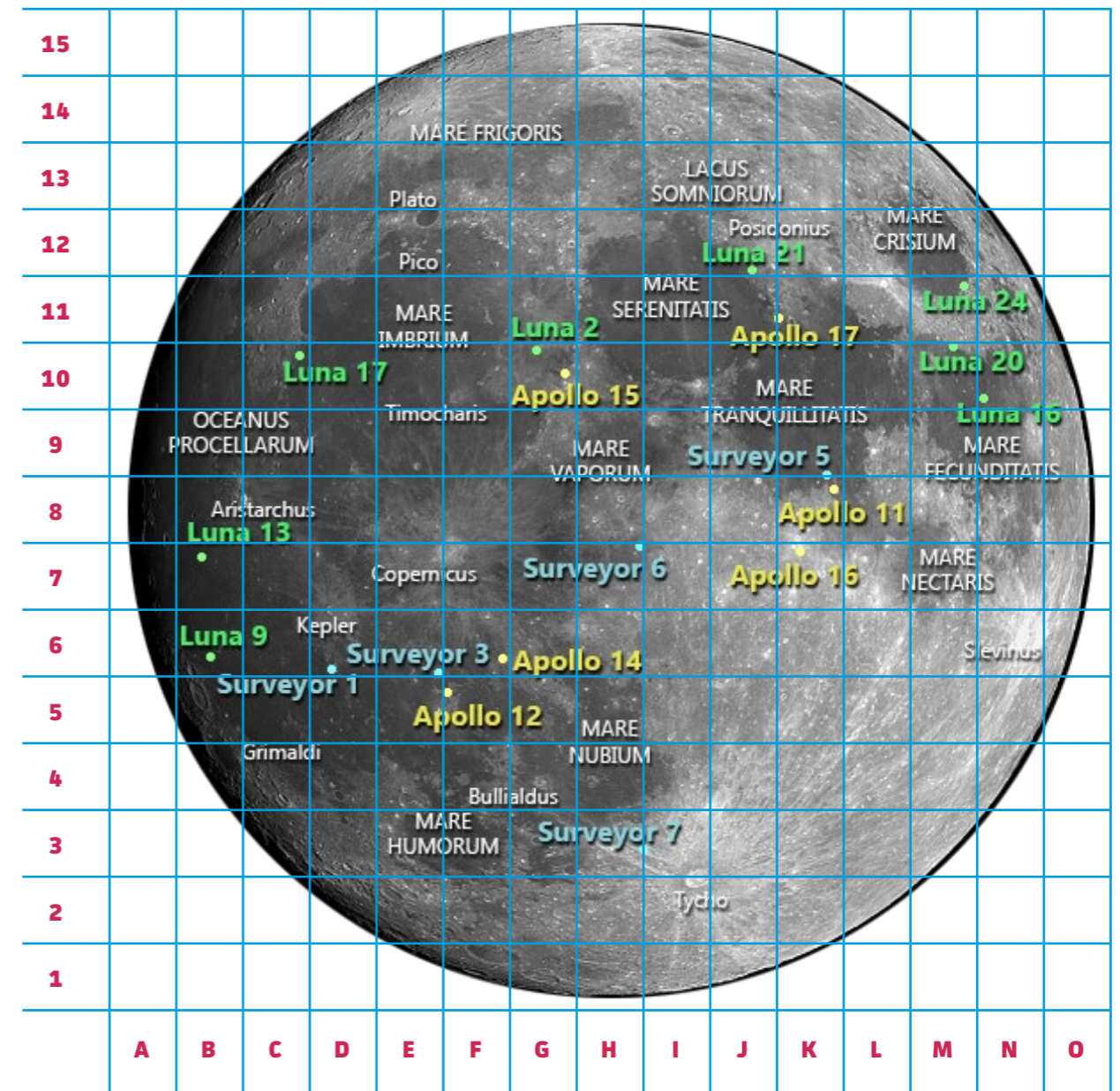

Activity Sheet 2b

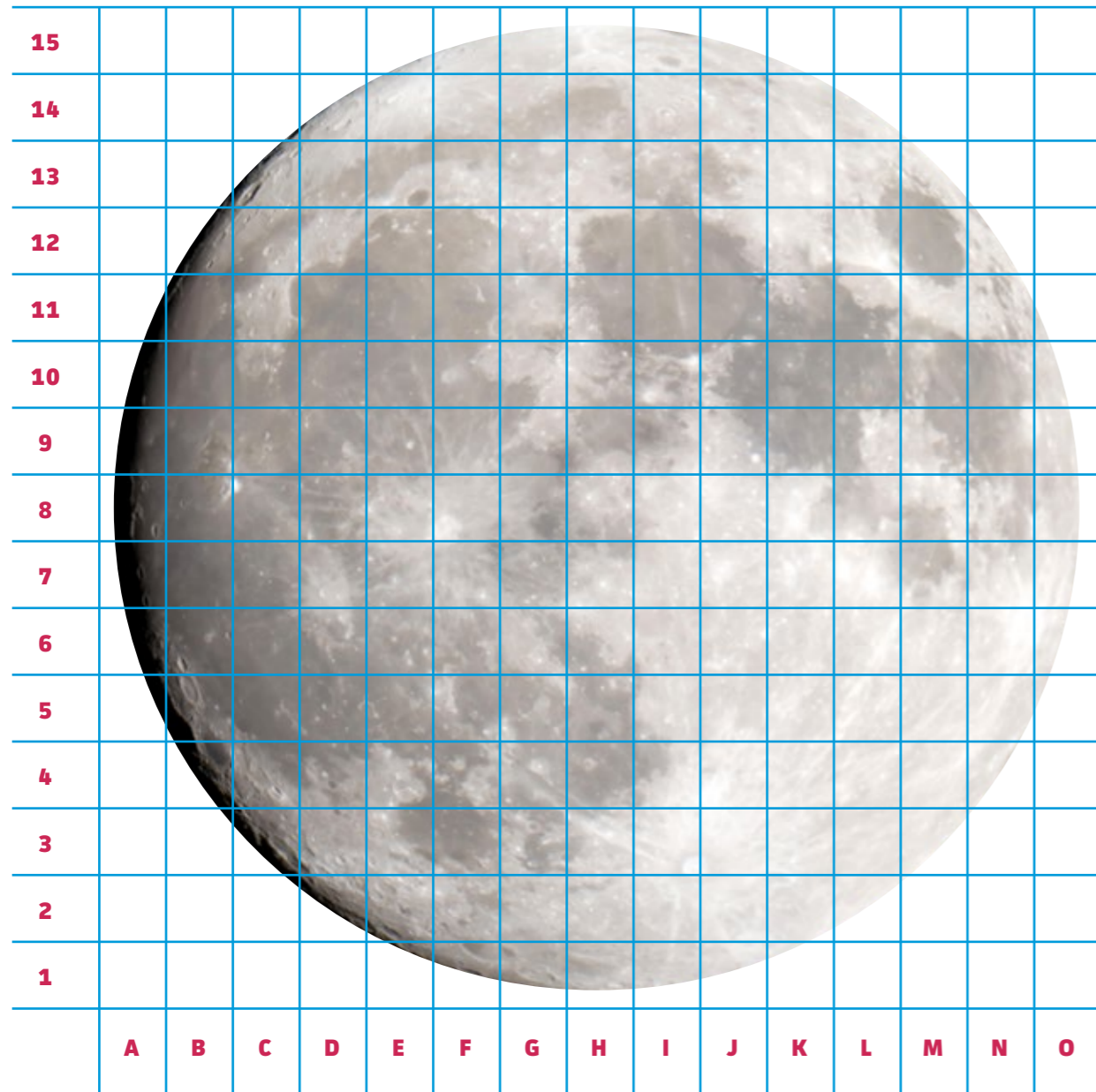

Activity Sheet 2c

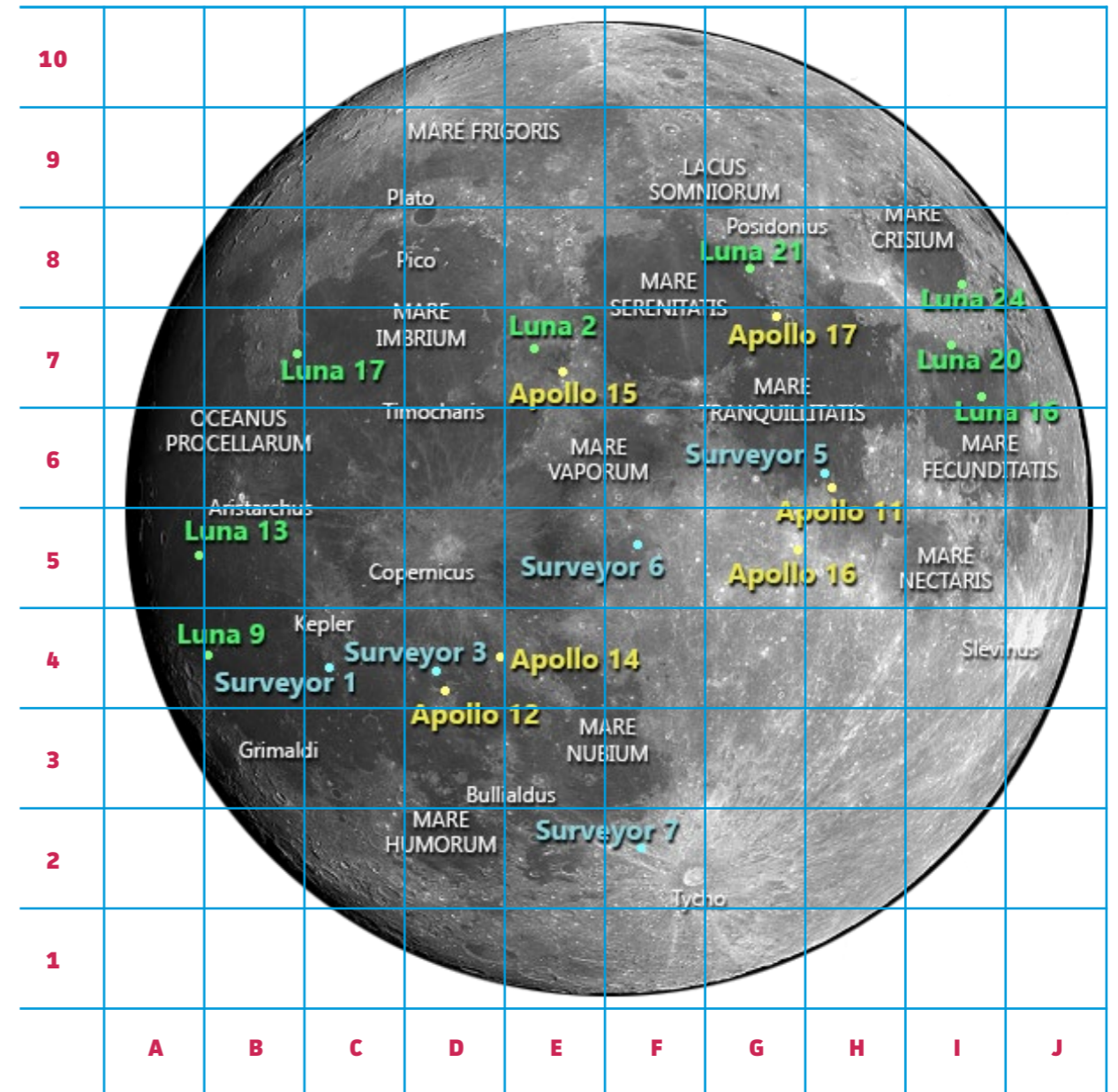



Activity Sheet 2d

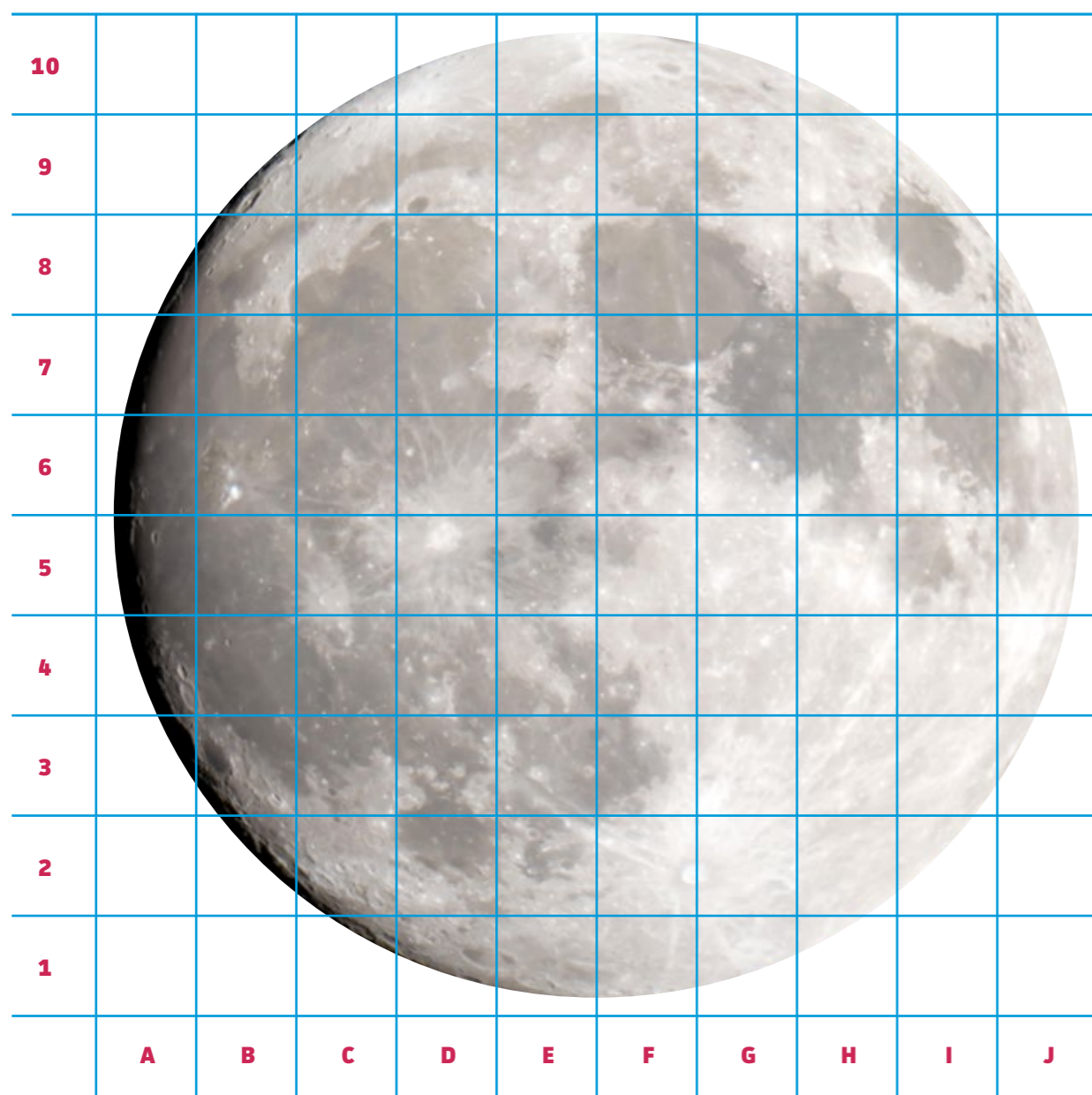

LAUNCHING 3 Lift Off! Up, Up and Away!

Astronauts have not ventured beyond Earth's low orbit since 1972 when NASA ended its Apollo programme. The European Space Agency (ESA) and Airbus have recently agreed with NASA to build a module for a manned mission to the Moon. They have already delivered a propulsion and supply module for an unmanned flight of NASA's new Orion spacecraft. In addition, several lunar probe missions are currently scheduled or proposed by various nations and organisations.



OBJECTIVES

- ★ An object will remain still unless a force is applied
- ★ For every action, there is an equal and opposite reaction
- ★ The distance travelled by a rocket is related to the force applied and the angle of launch

RESOURCES PER GROUP OF FOUR CHILDREN

- ★ 2-litre drink bottle
- ★ Short piece of 21.5mm PVC water pipe
- ★ Length of garden hose
- ★ 50cm of 21.5mm PVC pipe
- ★ Foam pipe insulation for rockets approx. 25cm
- ★ Card or plastic for rocket fins
- ★ Stickers or coloured paper for decoration
- ★ Sticky tape
- ★ Metre stick
- ★ Activity sheets 3a and 3b

In this activity, the children will investigate the forces required to launch a sponge rocket; they will test the effects of changing the design by adding fins (flights) to the rocket and measure the distance travelled.

★ ADVANCE PREPARATION

Build and test a rocket launcher. Copy the angle measurer from Activity sheet 3b onto card. The groups can share the rocket launcher. One for each group would be ideal.

Prepare role badges for rocket scientist, Appendix 1.

Introduce the lesson by showing a video clip of a rocket launch, eg Tim Peake's Soyuz launch in 2016: http://www.esa.int/spaceinvideos/Videos/2015/12/Principia_launch

What makes the rocket leave the ground?

Fuel called propellant is ignited to produce energy for the launch. Point out the shape of the rocket and the fins.

What do the fins do? Explain that fins help the rocket to travel in a straight path. The groups are going to make and test foam rockets.

What will the children need to do to launch their rockets?

Show the launcher and ask a volunteer to help demonstrate how it works. Holding the PVC pipe and supporting its lower end on a tabletop makes launching easier. The length of hosepipe attached to the pipe and bottle can be made long enough to reach to the ground, allowing the volunteer to stamp on the bottle at a distance from the rocket. (Simple air-powered rocket launchers may be purchased at reasonable cost on the internet if teachers prefer not to make their own.)



Challenge the children to make and test their rockets. *What must be kept the same each time to ensure a fair test? How could they improve on the distance travelled or the line of flight? Does adding weight to the nose of the rocket improve the distance travelled?* Allow the children time to change the number, shape or position of the flights on their rockets or make other adaptations they suggest.

★ **PLENARY**

Following further test flights, gather the results from each group and display on the whiteboard. Discuss the different designs and note any key features.

Ages 5 to 7: The children launch their rockets and mark distance travelled by placing a beanbag at point of touchdown.

Ages 7 to 9: Measure and record the distances travelled.

Ages 9 to 11: Launch each rocket three times and measure and calculate the mean distance travelled.

★ **EXTENSION**

Measure and record the distance travelled and the angle of launch each time. Repeat the launches and find the mean distance for angle of launch. The children might wish to record their data on the table on Activity sheet 3a. The angle of launch can be measured by holding the angle measurer on Activity sheet 3b with its base resting on the table (the launch pad) whilst at the same time holding the pipe against the measurer and the angle noted.

Do the groups have similar results? What do they notice? Is there a pattern? Are there any results that are unusual? Is there an ideal angle for launching?

Image shows Hari, aged five, testing the rocket launcher.

Activity Sheet 3a ★ Launching rockets

Angle of launch (degrees)	Distance (metres)	Distance (metres)	Distance (metres)	Mean distance (metres)
10				
20				
30				
40				
50				
60				
70				
80				
90*				

* Launching the rockets at this angle should result in the rockets landing in original launch position, if there is no wind. Which angle helps the rocket to travel furthest?

This is our rocket design:

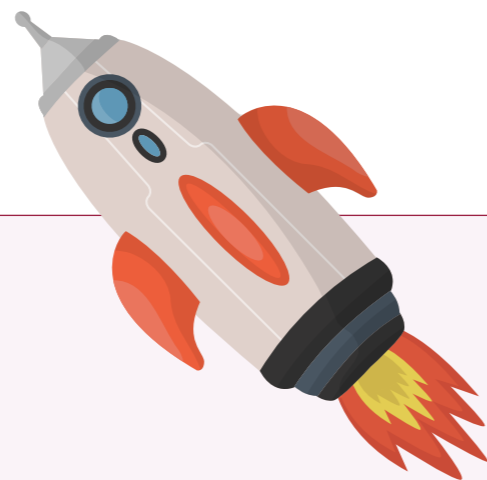

★ **TEACHER INFORMATION**

When a rocket is fired, a force accelerates the rocket into the sky. Rockets move upward by firing hot gases downward; the downward movement of gases causes an equal and opposite force, speeding up the rocket. The force pushing it upward (thrust) is greater than its own weight (force of gravity) pulling it downward, so the rocket climbs into the sky. Air resistance or drag also has to be overcome. The thrust of real rockets continues for a few seconds until the propellant is used up. Its mass gradually reduces but the mass of a foam rocket remains the same throughout its flight. The fins of the foam rocket keep the rocket pointing in the desired direction.

Teachers may wish to let the children build simple catapults from craft or ice lolly sticks as an alternative to the drink bottle launcher.

★ **INSTRUCTIONS FOR CONSTRUCTING ROCKET, ROCKET LAUNCHER AND ANGLE MEASURING DEVICE**

Attach a 2-litre drink bottle via its open top to a short length of 21.5mm PVC pipe.

Next, attach a length of garden hose to the short piece of PVC pipe.

Attach approximately 50cm length of 21.5mm PVC pipe to the garden hose.

Use a sufficient length of hose to allow the drink bottle to be positioned a short distance from the launch and for the PVC pipe to be manoeuvred at different launch angles.

Cut a length of foam pipe insulation to the required length for a rocket, eg 25cm.

Fold over the end of the foam at the top of the rocket and tape it down to avoid air escaping at launch.

Cut a 10cm square of thin card in two, diagonally. Mark the centre line on each triangle. Then on each triangle, mark a line 1cm from, and parallel to the centre line, on either side. Fold along these lines to form two fins.

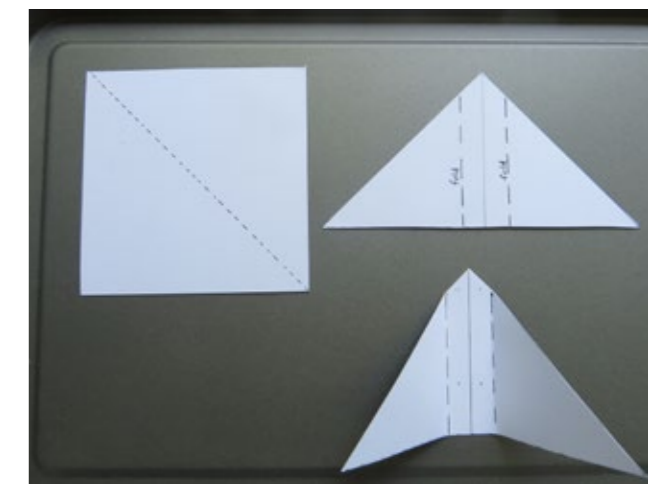

Tape each set of fins opposite to one another at the tail of the foam rocket.

Finally slide the rocket over the end of the PVC pipe.

Stamp on the drink bottle to launch the rocket.

If necessary, adjust the fins to help the rocket fly on a straight path.

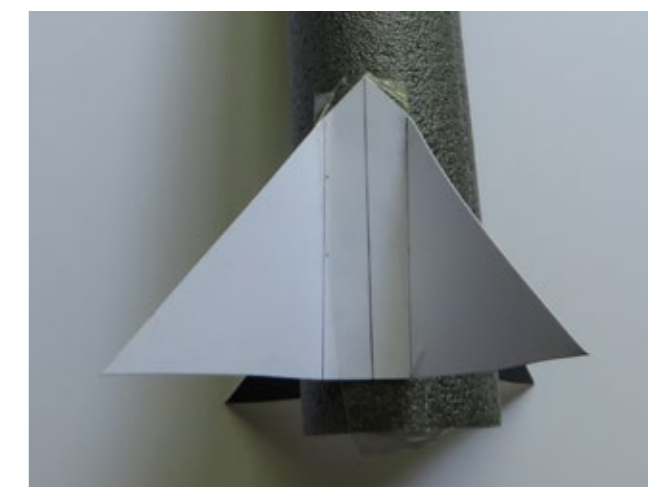

Activity Sheet 3b

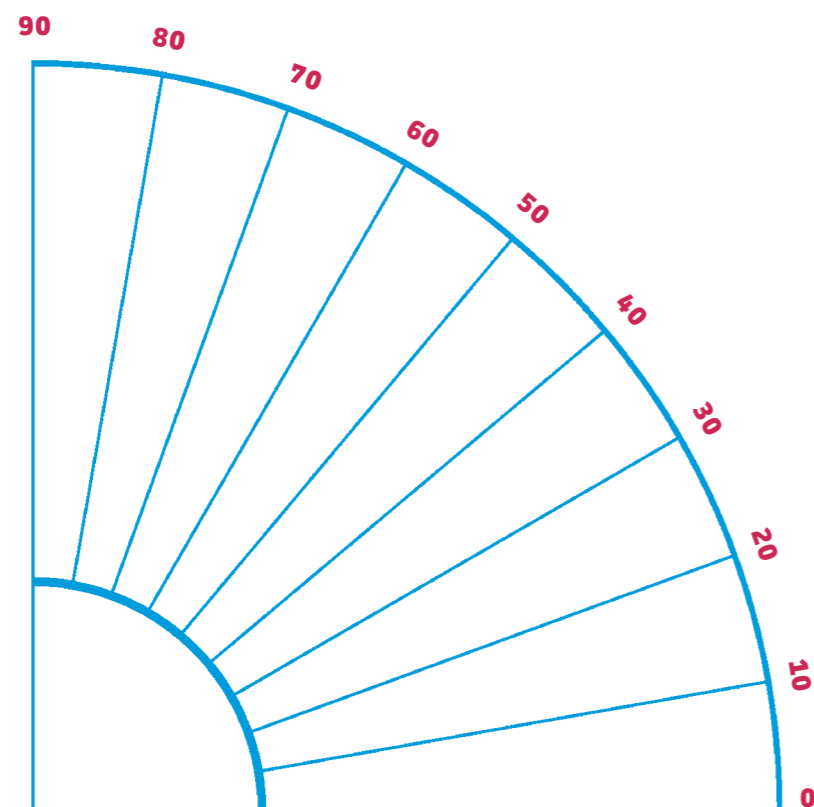

★ INSTRUCTIONS FOR MAKING A SMALL CATAPULT FROM LOLLY STICKS

RESOURCES PER GROUP OF FOUR

- ★ Lolly or craft sticks x 10
- ★ Rubber bands x 3
- ★ Small marshmallows
- ★ Plastic spoon (optional)
- ★ Drink bottle lid

Place eight sticks one on top of each other and secure the bundle at each end with a rubber band.

Join a further two sticks together by loosely winding a rubber band 1cm from one end.

Push the bundle of eight sticks between the two sticks, up to the rubber band join.

Pressing the end of the upper stick downwards and releasing it should launch a small object, such as a marshmallow, into the air.

A plastic bottle lid may be attached to hold objects if preferred. Alternatively, a plastic spoon can be attached by rubber band to the upper launching stick and the object to be launched placed in the spoon.

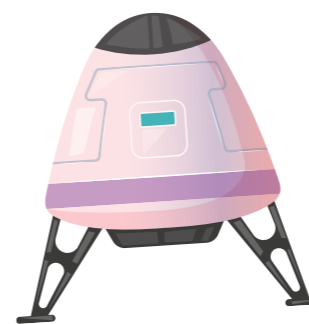

LANDING 4 Gently Does It!

The science explaining how to fly to the Moon was actually worked out in the 17th century but it took until the middle of the 20th century for the technology to be developed to make a lunar landing possible. Landing on the lunar surface is very difficult because of the Moon's lack of atmosphere; friction cannot be used to reduce speed and parachutes are of no use for the same reason. Very careful deceleration of the engines is required, landing gently on the rocky surface, avoiding possible destruction of the module or disturbing layers of dust that could affect instruments.

OBJECTIVES

- ★ Explain why unsupported objects fall to Earth
- ★ Explain why lunar craft need to make gentle landings
- ★ Select materials based on their properties
- ★ Follow the engineering process of design, build, test and amend

RESOURCES PER GROUP OF FOUR CHILDREN

- ★ A selection of suitable craft materials
- ★ Scissors
- ★ Paper
- ★ Straws
- ★ Paper cups
- ★ Cardboard
- ★ Sticky tape
- ★ Rubber bands
- ★ Bubble wrap
- ★ Cotton wool balls
- ★ Model figures or marshmallows x 2
- ★ Pieces of sponge



Image shows Lunar Landing Research Vehicle 1964
Credit: NASA

In this activity, the children build a landing craft and design a method to enable their model to land gently without damage.

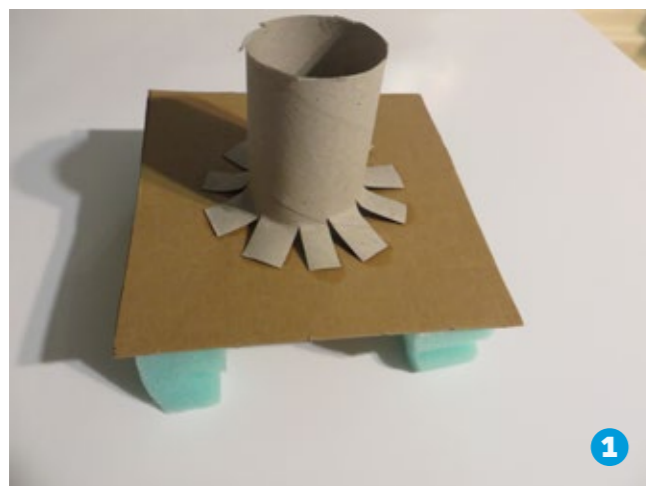

1



2

★ **ADVANCE PREPARATION**

- A set of role badges for aerospace engineer, Appendix 1
- A spring for demonstration

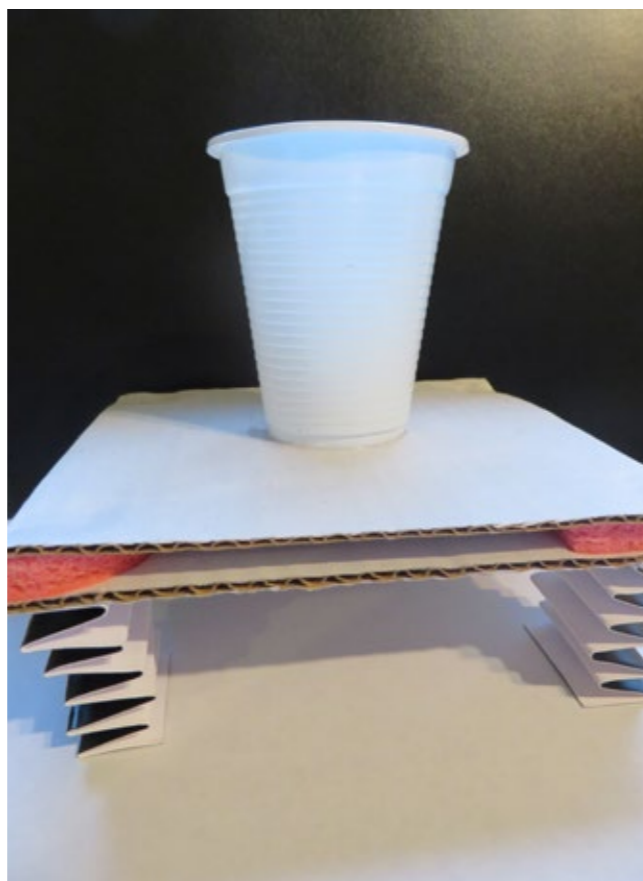

Construct a demonstration lander using two pieces of card with a few pieces of sponge or similar shock-absorbing materials between the two cards, or use one card with four legs made from sponges or springy card attached underneath; a 'cabin' glued on top will hold the 'astronauts'. Several cards, each with four landing legs made from a different material, could be prepared. Attaching these in turn to the upper card using rubber bands will enable several different tests to be performed, one after another.

★ **INTRODUCTION**

The children watch a video clip of a lunar landing (link: Apollo 11 lunar landing 20 July 1969): https://youtu.be/k_OD2V6fMLQ

What did they notice about the landing? What would engineers have to think about when designing and building a lander? Why could a parachute not be used to slow down the lander?

Explain that the lander or 'module' carrying astronauts down to the Moon's surface has to land gently in an area of the Moon that is free from rocks, craters and other hazards to avoid injury to the astronauts or damage to the instruments. The moon does not have any atmosphere, so a parachute would not have any effect.

Show the children the materials and explain that they are going to take on the role of **aerospace engineers** to design and build a simple lander to protect two 'astronauts' when they land. The lander must be able to carry a 'cabin' containing the 'astronauts' and land upright when dropped without damage to the lander or loss of astronauts. They can design, test and improve their landers before demonstrating to the class.

Ask the children to demonstrate how they land when jumping from a height; they bend their knees to absorb the shock on touching the ground. Try it!

Show the children a spring and show how it deforms when pressed or when it is dropped onto a surface. Explain that this is how a shock absorber works, by absorbing the shock of an impact. If possible, provide springs for the children to handle. *Can the children suggest other soft, springy materials that squash and spring back to their original shape or size after impact?* Challenge them to fold a piece of paper to produce a spring. Some may suggest a concertina design; show how folding paper back and forth can produce a paper spring that will deform and bounce back. *Can they think of other materials to help astronauts land softly?* Have a variety of materials available after discussion. *How might they use the materials provided?*

In groups, the children discuss and plan their designs. Show the children the demonstration lander if they need support. Once satisfied with their designs, they build their model landers, attaching a small container to the platform to represent a cabin for the two 'astronauts'. Set the height of the drop so that all landers may be compared. The groups assess their designs and make alterations as required.

★ **PLENARY**

Discuss the designs and the changes each group made to their landers. *What problems did they encounter? What changes did they make? What advice would they give to aerospace engineers designing future Moon landers? Why is landing on the Moon different from landing on Earth? How might the lunar surface affect the landings and equipment on board?* Remind the children that engineers frequently encounter problems and must amend their designs to achieve success.

★ **EXTENSIONS**

- The groups could investigate:
- increasing the height of drop
 - testing springs of different sizes
 - varying the landing surfaces
 - changing the size of the lander

★ **PROBLEM-SOLVING**

The children may encounter some issues that require changes to their designs. This is to be expected and mirrors how design engineers work. If the landers tip in the air, they might change the position of the cup or reposition the shock absorbers. The platform should be heavier than the cabin to ensure a smooth drop.

The landers may bounce instead of landing gently, ejecting the astronauts. If this happens, the children might try reducing the size of the springs or the number of springs or absorbers.



LIVING & EXPLORING

5 Rolling Along

An engineering design challenge

OBJECTIVES

- ★ Follow the engineering design process to build, test and improve a prototype rover
- ★ Discover how rubber bands can be used to provide energy for movement
- ★ Use a variety of everyday materials based on their properties

RESOURCES PER GROUP OF FOUR

- ★ Activity sheet 5a
- ★ Circular pencil, long lolly stick or wooden skewer axle x 2
- ★ Plastic milk bottle tops x 2
- ★ Plastic coffee tin lids x 2
- ★ Small box lid for the chassis x 1 (or corrugated cardboard 15cm square)
- ★ Scissors
- ★ Rubber bands
- ★ Matchstick
- ★ Beads as spacers for the axles x 10
- ★ Glue
- ★ Double-sided tape or glue
- ★ Tyre 'treads' to stick to wheel, eg wool, string, card or straws
- ★ Ruler
- ★ Square and triangular front wheels from corrugated card x 2



LUVMI – Lunar Volatile Mobile Instrumentation – is a wheeled lunar rover weighing 40kg being developed to explore the polar regions of the Moon. It will drive to areas of permanent shadow where sunlight doesn't reach and where temperatures are extremely low. If water exists on the Moon, it might be found in the form of water ice on, or under, the lunar surface. The rover will analyse rock samples by inserting its probe into the surface, heating samples and testing the volatiles produced. It is important that the wheels of the rover are designed for maximum grip when navigating the dusty lunar terrain. Follow this link to watch a video clip of LUVMI: <https://www.youtube.com/watch?v=iq-m03c7VF0>

Co-funded by the Horizon 2020 Framework Programme of the European Union, grant agreement 727220



★ ACTIVITY

In this activity, the children take on the role of **space engineers** to build and test a lunar rover. They go on to adapt designs for the shape or treads of its wheels and investigate ways of improving its function.

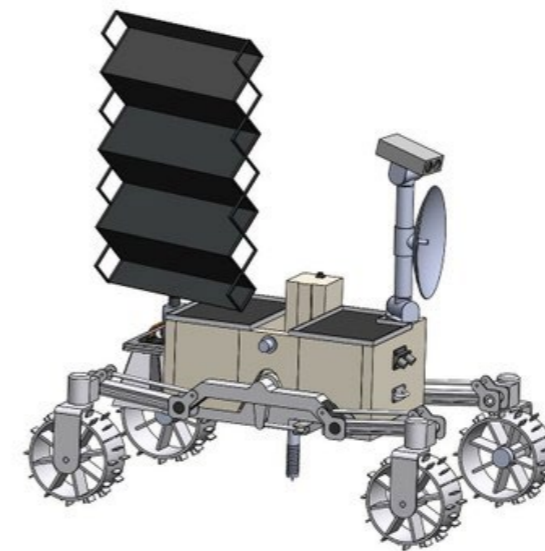

Image credit: **Open University**

★ ADVANCE PREPARATION

A set of role badges for space engineers, Appendix 1

Build a prototype rover to test, following the instructions found in the teachers' information section.

Collect boxes, sets of 'wheels' from plastic coffee lids, plastic milk bottle lids and cut corrugated cardboard if required. Insert holes in each.

★ INTRODUCTION

Introduce the lesson by watching a short video of a lunar rover in action on the Moon (link to Apollo 17 rover: <https://youtu.be/sRSptQ-VtY>).

Explain that the last lunar landing took place in 1972 and no one has since landed on the Moon. Many countries are currently discussing plans to send astronauts to the Moon, hoping to learn more about its physical features and to investigate its natural resources. One day, shelters, homes and even villages may be built there, where humans could live. Before this can happen, vehicles called lunar rovers will be sent by spacecraft to land on the Moon. They will travel across the Moon's surface, drilling for samples and testing for key ingredients that would be useful to astronauts setting up a base there. *What do the children think would be needed by future astronauts?*

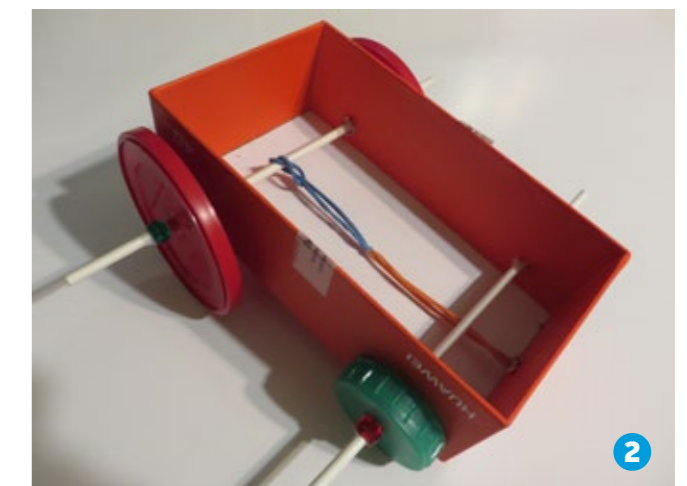
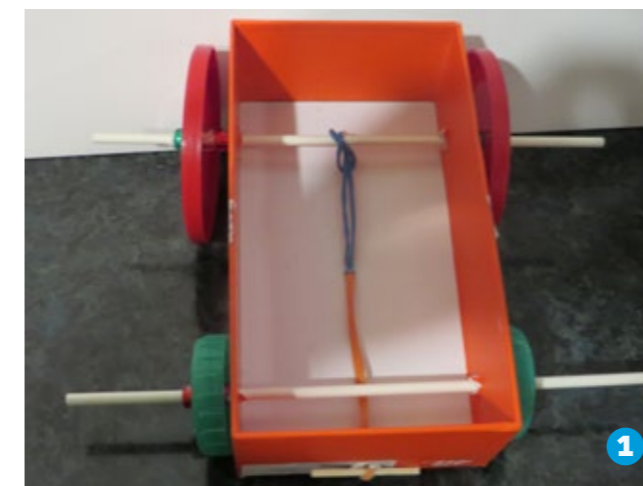

Next, show the children images of rovers such as Mars Curiosity rover or ExoMars: https://www.esa.int/spaceimages/Images/2017/03/ExoMars_rover

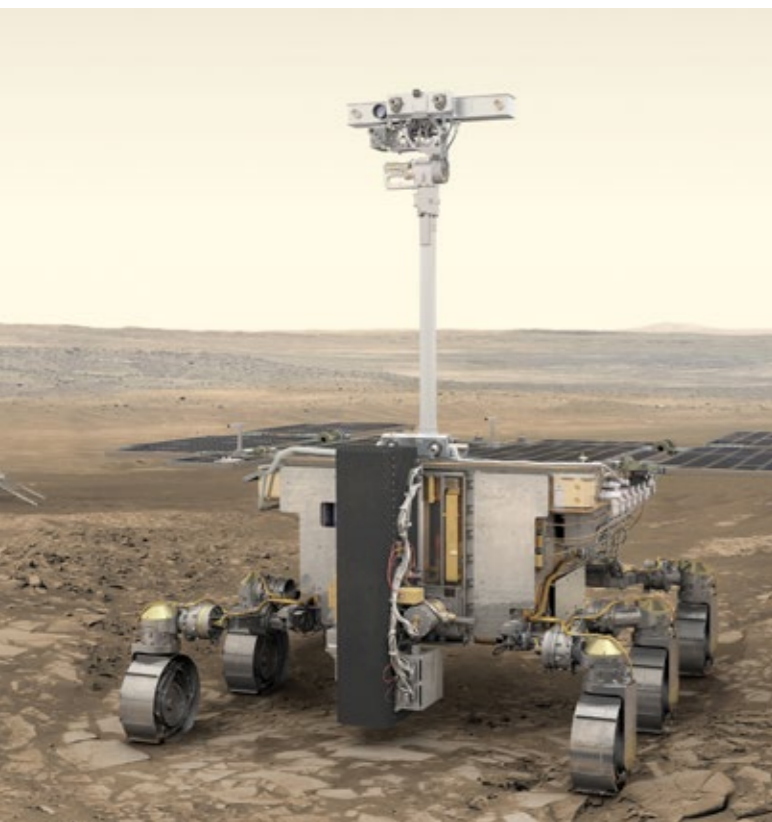

Explain that there are a variety of possible designs and that engineers are busy planning, building models, testing and, where necessary, changing and improving their prototypes. Highlight a few key features of each rover.

Discuss the challenges faced by the lunar terrain and explain that the rovers must be tough and have wheels that can grip the surface and not sink down into the Moon's dusty coating.

Today, the children are going to act as **space engineers** to build a lunar rover prototype using the materials provided, test it on a flat surface and make any improvements required. They can measure how far the rover travels as the rubber band is increasingly tightened by turning the front wheels before releasing. They could plot a graph to show distance versus number of turns of the wheels.

After initial testing, compare the vehicles from each group. *Which travelled furthest? Which travelled in a straight line? Could the rovers be improved? How?*

The groups discuss ideas for improving and adapting their rovers and draw their designs using Activity sheet 5a. They collect the materials required, adapt their rovers and retest. *Did their new designs and adaptations improve the rover? Was it able to travel further or in a straighter line?*

★ **EXTENSION**

Challenge the children to devise further investigations to try. Suggestions might include:

Can the rover travel over different surfaces, eg smooth, bumpy, inclined?

What would be the effect of using corrugated cardboard wheels? What effect might changing the wheel shape have?

How might we change the wheel surfaces to provide extra grip?

Can the rover withstand meteoritic bombardment? How could we test this?

Activity Sheet 5a ★ Testing a lunar rover prototype

Number of winds of wheels	Distance 1cms	Distance 2cms	Distance 3cms	Average distance cms

Make these changes to improve the rover:

Second test

Number of winds of wheels	Distance 1cms	Distance 2cms	Distance 3cms	Mean distance cms

We found:

★ **TEACHER INFORMATION**

The Apollo lunar roving vehicle was a battery-powered space buggy. The astronauts on Apollo missions 15, 16 and 17 used it to explore their landing sites and to travel greater distances than astronauts on previous missions. It was designed to carry two astronauts and was manually driven. It could climb steep slopes, go over rocks and move easily over the Moon's regolith. Its wheels were made from wire mesh like piano wire with titanium studs for treads. Rubber tyres would have been much heavier for the spacecraft to carry. Air would escape from the tyres due to the absence of any external pressure since the Moon does not have an atmosphere.



★ **INSTRUCTIONS FOR BUILDING A LUNAR ROVER PROTOTYPE**

Use a small cardboard box lid as the rover chassis body. The example shown in the image measures 15cm long, 5cm deep and 8.5cm wide. A piece of corrugated cardboard 15cm square, folded in three along the lines of the corrugation may be used instead.

Make a hole in the centre of each plastic coffee tin lid to ensure the axle will fit tightly.

Make a hole larger than the axle diameter in the centre of each milk bottle lid.

Make a small hole on each side at the front of the chassis, approximately 1cm up from the base and on opposite sides.

Smooth the sides of the holes if rough.





Make a hole on each side of the chassis at the back of the rover 1cm above the base and on opposite sides. Cut a small hole 1cm up from the base at the rear end of the chassis.

Insert the front axle to pass through the holes at the front; ensure it rotates loosely.

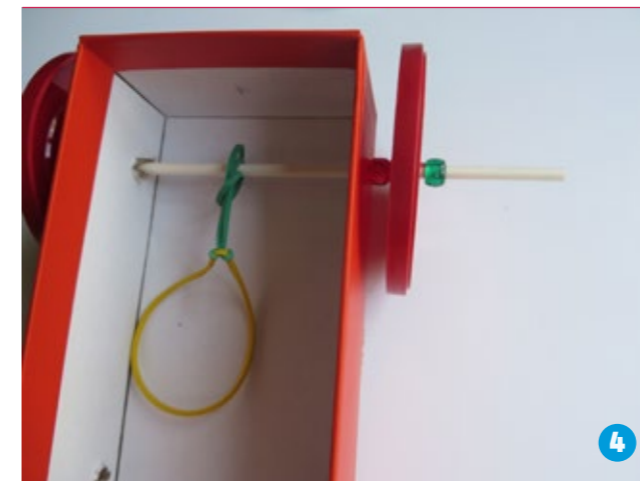

Next, push each end of the front axle through the centre point of each of the larger wheels, and push each wheel up to the beads. Finally, thread a bead on each side of the axle and push up to the wheel. Add a drop of glue to prevent the beads moving.

Ensure the front wheels and axle turn together when turned.

Join together two rubber bands. Hold one end of the rubber bands on the front axle and feed the length of the rubber bands through this loop and through the hole at the back end of the chassis. Secure the end of the rubber band outside the chassis hole with a matchstick.

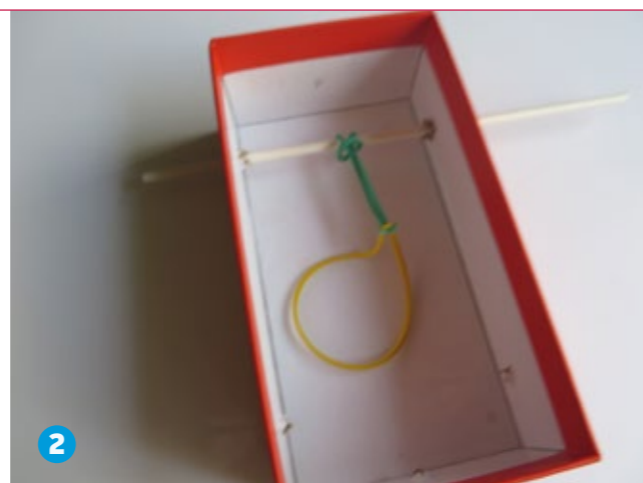

Slide a bead on each side of the rear axle as spacers, push a milk bottle lid onto each end of the rear axle ensuring the wheels rotate, but NOT the axle this time, and add a further bead pushed up to each rear wheel. Glue the beads in place.

Wind the front wheels using the axle, so that the rubber band winds over itself, shortens and stores energy.

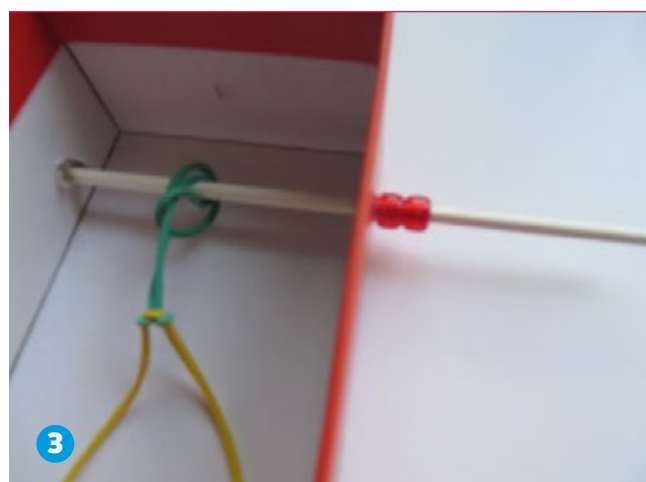
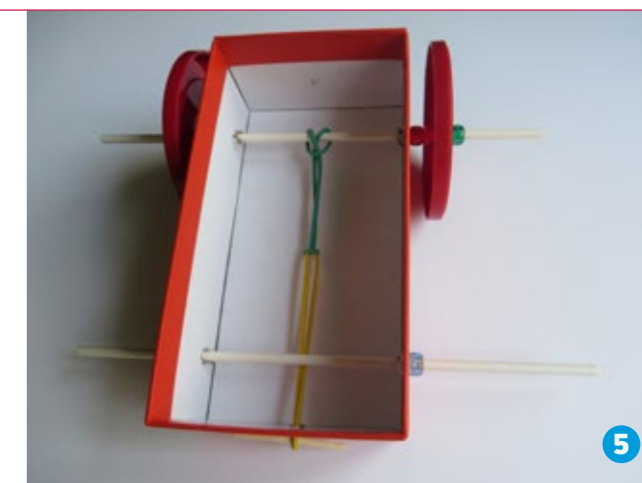

Insert the rear axle through the holes. It should fit tightly without rotation.

Next, thread two beads on each side of the front axle to act as spacers. Glue the beads in position.

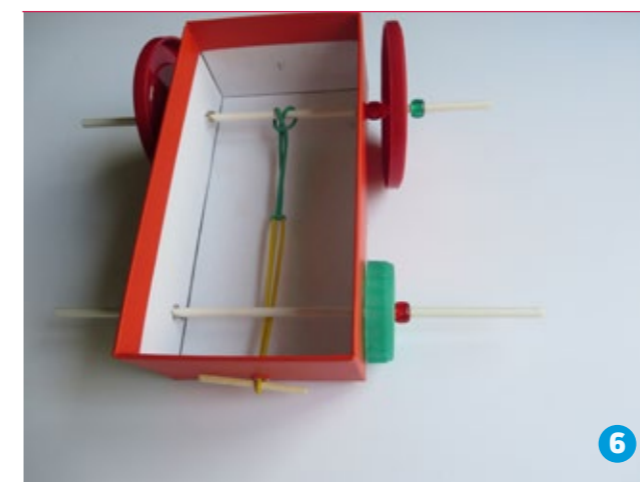

Let the rover move on the chosen surface.

Try two square front wheels made from corrugated cardboard. Cut out two squares of suitable size. Draw the diagonals on each wheel and mark the centre points where the diagonals intersect.

LIVING & EXPLORING

6 Water, Water Anywhere?

In this activity, the children try to find the best location to drill for water on the Moon. Working as lunar geologists they:

- ★ investigate samples of mock lunar 'soil', known as regolith, from different locations on the lunar surface. They measure the volume of water trapped in each sample and determine whether the size of soil particles affects the volume of water that can be stored in the soil.
- ★ test for the presence of pure water using universal indicator paper.
- ★ use information about lunar geology to match each sample with its location on a Moon map and suggest the most suitable place for a lunar rover to drill for water ice.

Lunar scientists are increasingly confident that water can be found in a variety of places on the Moon, locked in minerals, in small pieces of ice mixed with regolith scattered across its surface and, potentially, in blocks of ice at depth. Although water cannot exist in liquid form on the lunar surface due to solar radiation, some deep craters near the poles never receive sunlight because of the slight tilt of the Moon's axis as it spins and are permanently in shadow. The temperature in these regions averages -170°C and can drop to -240°C , so any water here could have remained frozen for billions of years.

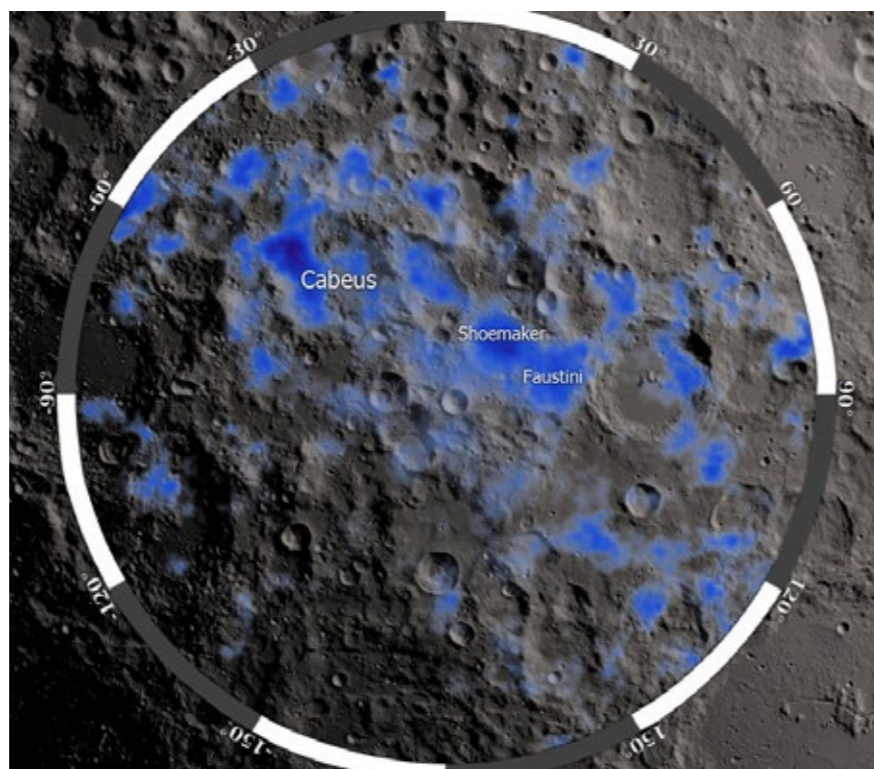

OBJECTIVES

- ★ The Moon is covered in regolith, containing dust, lunar soil and rock
- ★ Water in the form of water ice may be trapped under the surface
- ★ The volume of water soil can hold depends on soil particle size and the porosity or spaces between those particles
- ★ Polar regions of the Moon are in permanent darkness
- ★ Energy from sunlight can melt water ice

RESOURCES PER GROUP OF FOUR*

- ★ 100ml measuring cylinder
- ★ Bowl or container
- ★ Sieve
- ★ Samples of mock lunar regolith A, B, C, D in disposable cups
- ★ Funnel or jug
- ★ Activity sheet 6a (lunar sample description)

*Teachers could prepare fewer samples, ask each group to test just one or two samples and share results, if preferred

Activity A

★ ADVANCE PREPARATION

Role badges for **lunar geologist**, Appendix 1

Four samples of mock lunar regolith ranging from fine grit, gravel to larger pebble sizes. (Pet shops sell aquarium pebbles, sand and gravel in various colours including black, grey and white.)

Each group will require a small disposable cup of each of the following, labelled accordingly:

- **Sample A** light coloured stones approx. 2 to 3cm in size
- **Sample B** white gravel
- **Sample C** mixture of $\frac{3}{4}$ white gravel and $\frac{1}{4}$ black grit
- **Sample D** black grit

Pour water into each cup until completely full

A dry sample of each 'regolith' on a paper plate for the children to observe

Weighing scales – optional

★ INTRODUCTION

Show the children an animation showing the orbit of the Moon around the Earth: http://www.esa.int/spaceinvideos/Videos/2018/10/Paxi_and_Our_Moon_Phases_and_Eclipses Explain that the polar regions are permanently in darkness. Sunlight cannot reach them because the axial tilt in the Moon's orbit is too small. Consequently, these areas are always very cold, well below the freezing point of water. *If water is there, what form would it take?* Explain that humans hoping to set up a habitat on the Moon will need a supply of water for drinking. Discovering a supply of water could be vital for future missions. Before we send humans on missions to the Moon, rovers and probes brought by rockets will drill the surface to take samples and test for the presence of pure water.

Display on the whiteboard a large detailed image of the Moon and explain that scientists think that different areas of the Moon may contain water below the surface in the form of ice. Point out that the Moon is coated in a very fine dusty surface and rocks of various sizes. Deeper down, the regolith is more solid but the exact composition varies across the Moon.

Do the children think that different kinds of rocks and soils will hold different amounts of water?

Show the children the dry samples of mock lunar regolith and explain that today they will take on the role of **lunar geologists**. They will be provided with four water-containing lunar samples A, B, C and D, taken from four different locations 1, 2, 3 and 4, on the lunar surface and their mission is to separate the water from the regolith in each and measure the volume of water each contained. Finally, they will use information from the key on Activity sheet 6a to determine where on the lunar surface the samples were obtained.

The groups assign job roles, plan how they will separate the regolith from the water, select resources required, decide on the method of recording their results and make predictions.

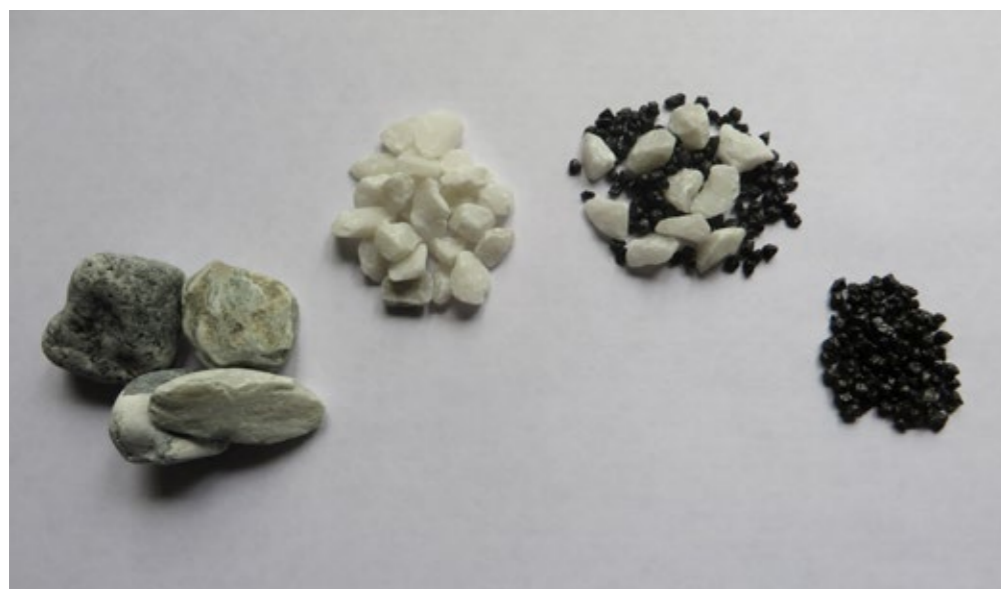

Image shows samples of mock lunar regolith A, B, C and D

★ PLENARY

The groups report their findings. A table showing the data for all groups could be displayed on the whiteboard. Discuss the results for each group.

Did the volume of water contained vary between the soil samples? Which, if any, regolith contained most water? What size particles did this regolith contain? What colour were they? Can they explain why they held different volumes of water? Where do they think the sample came from?

The children may suggest that some water might have been absorbed by the regolith.

How could we find out? The samples could be weighed before and after the investigation. Where would they recommend a rover to be sent to dig for water ice on a future mission to the Moon and why?

OBJECTIVES

- ★ Ingredients in soil can dissolve in water in the soil
- ★ Soil ingredients can determine its acidity
- ★ Indicator paper can be used to test the acidity of a liquid

RESOURCES PER GROUP OF FOUR PUPILS

- ★ 4 samples of 'mock' lunar ice melt A, B, C, D
- ★ 4 universal indicator paper test strips
- ★ Activity sheet 6b with universal indicator colour match chart

Activity B

★ ADVANCE PREPARATION

Half fill four small containers, eg ice-cube trays, with water. Add vinegar to one (sample A), a few drops of vinegar to another (sample B), water only in the third (sample C) and soapy water (from a bar of soap) or sodium bicarbonate to a fourth (sample D). Prepare sufficient samples to provide four per group. Label the samples A, B, C and D. Test the pH of the samples using universal indicator paper. They should range from acidic pH3 to 4 (vinegar), mildly acidic pH5 (more diluted vinegar), neutral, pH6.5 to 7 (water) to alkaline pH8 to 10 (sodium bicarbonate or soap).

★ ACTIVITY

Explain that water can absorb ingredients from soil. Scientists test whether or not the water is acidic by using a special paper called universal indicator paper. Regolith from different areas of the lunar surface may contain water producing different colour changes. The children test the four samples and record results.

★ PLENARY

Explain that regolith from the highlands tends to be lighter in colour and more acidic than regolith from the maria or seas. *Did any sample contain pure water? Which sample/s was acidic? Where would they recommend a lunar rover to dig?*

Read about the work of Hannah Sargeant (Appendix 2), a geologist looking at ways to create water from Moon rocks!

★ EXTENSION/FURTHER INVESTIGATIONS

- Do rocks or stones absorb water? Do different kinds of rocks or stones absorb different volumes of water?
- If astronauts extracted water ice, how could they change it to a liquid? What conditions can you think of to melt ice?
- Does the thickness of ice affect its melting rate?
- Does the colour or material of the surface on which it is placed affect the melting rate of ice?
- Will ice deep down in soil melt more slowly than ice near the surface?
- Is the melting rate of ice affected by the amount of regolith it contains?



If the children investigate whether a dark or light surface affects the melting rate of water ice, the concept cartoon on Activity sheet 6c could be used to help them make predictions.

Different thicknesses of ice, some containing regolith, could be prepared using a range of volumes of water frozen in disposable cups. The children record which melt most quickly or slowly. Graphs can be plotted of depth of ice (cms) versus time taken to melt (mins). Children may simply compare the volume of melted ice by carefully pouring water from each melted sample into identical transparent plastic tubes and placing them side by side. If, at timed intervals, the children pour the water from the melted ice into a measuring cylinder or graduated beaker and record the total each time, a graph could be drawn of volume of water in ml versus time. Planning boards and tables for results could be provided if children require support.

Each group presents its results to the class.

What did they discover? Did the cubes melt more quickly on a light or dark surface? Did the surface material affect the rate of melting? Was it a fair test? What did they keep the same? Might the position of the sample or its location affect the results?

What advice would they give to future astronauts trying to obtain water on the Moon?

Remind the children that water cannot exist in liquid form on the Moon because there is no atmosphere. In the absence of atmospheric pressure, ice would change from solid to gas immediately. We call this sublimation. Show the children an example of this using the following link:

<https://youtu.be/JoH7sdCaa4g>

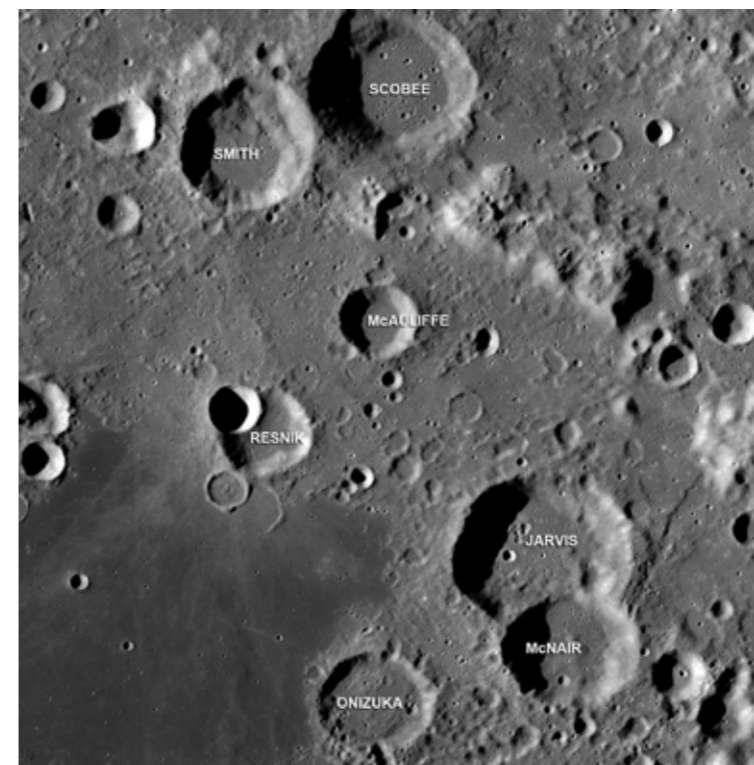

Image shows craters on the lunar surface, from Wiki Creative Commons

★ TEACHER INFORMATION

Lunar water has two potential origins: water-bearing comets striking the Moon and production on the Moon itself. In 2009, NASA launched a small spacecraft called LCROSS – Lunar Crater Observation and Sensing Satellite – developed by NASA Ames to travel to the Moon on the back of a large rocket to look for water ice at the lunar South Pole. Plumes of water thrown up as the spacecraft collided with the surface could be analysed for the presence of water. Water can provide liquid vital for life but also oxygen, hydrogen, steam for nuclear power and a protective layer against radiation. Missions such as this, to learn more about the lunar surface, are preparing for the return of astronauts to the Moon by mapping suitable landing sites that might provide valuable resources. Satellite data suggests

that water exists deep inside the Moon and that volcanic rocks may also be a source of this valuable resource. Tiny glass beads that formed from crystallised magma left over from previous volcanic eruptions, collected as part of the Apollo 15 and 17 missions were analysed and found to contain traces of water. A study suggests these deposits are widespread (Source: Brown University July 2017; Journal reference; Nature GeoScience 2017). Future astronauts visiting the Moon could one day extract water from these beads rather than transporting supplies from Earth. The presence of large quantities of water on the Moon would mean that human habitation there could be possible. Water ice could be melted to provide water for drinking and growing crops and the water could also be split into oxygen for breathing and hydrogen for rocket fuel.

Activity Sheet 6a ★ Water, Water Anywhere?

MOON MAP SHOWING LOCATIONS

KEY

(map of near side of moon, highlands, craters, maria)

- 1 Mare (sea) – very dark areas of black basalt
- 2 Highlands – light areas of rock
- 3 Highland crater – many craters are found in the highlands, mainly white igneous rock
- 4 Smooth highland plains – mixture of light-coloured rock plus black basalt exposed by meteorites crashing onto surface and onto craters

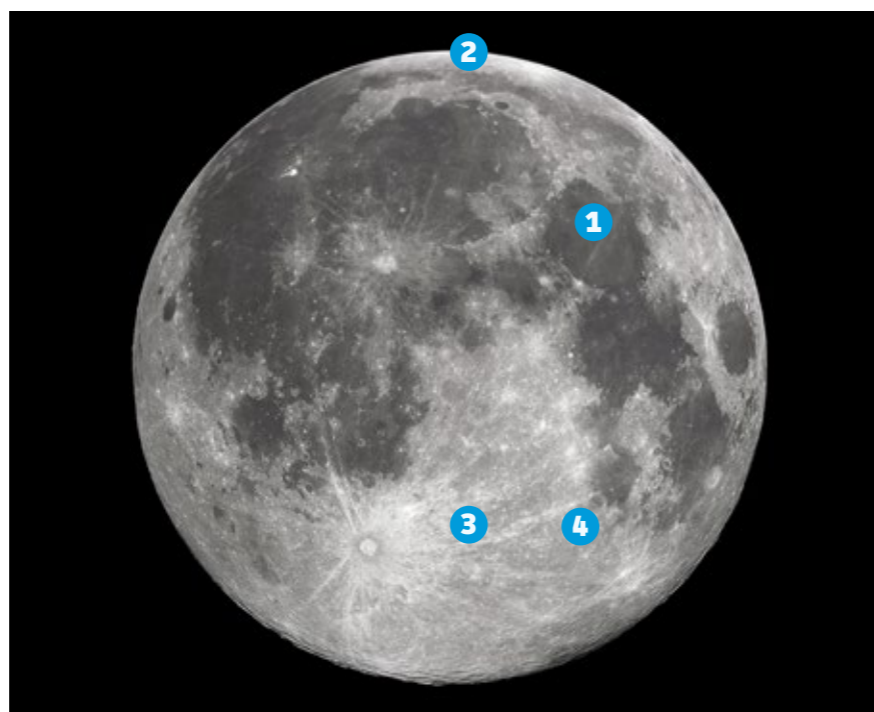

Sample (A, B, C or D)	Moon location 1, 2, 3, 4	Mare, crater or rim	Regolith colour	Regolith name	Acid test
		Highlands	White or grey pebbles	Anorthosite (igneous calcium silicates, feldspar)	Acid
		Highlands crater	Small white	Anorthosite	Acid
		Smooth highland plains	½ white ½ black	Breccia (rocks broken by meteoroid impact)	Neutral Pure water
		Mare	Black	Igneous basalt from cooled lava	Alkali

Activity Sheet 6b ★ Water, Water Anywhere?

TESTING FOR PURE WATER

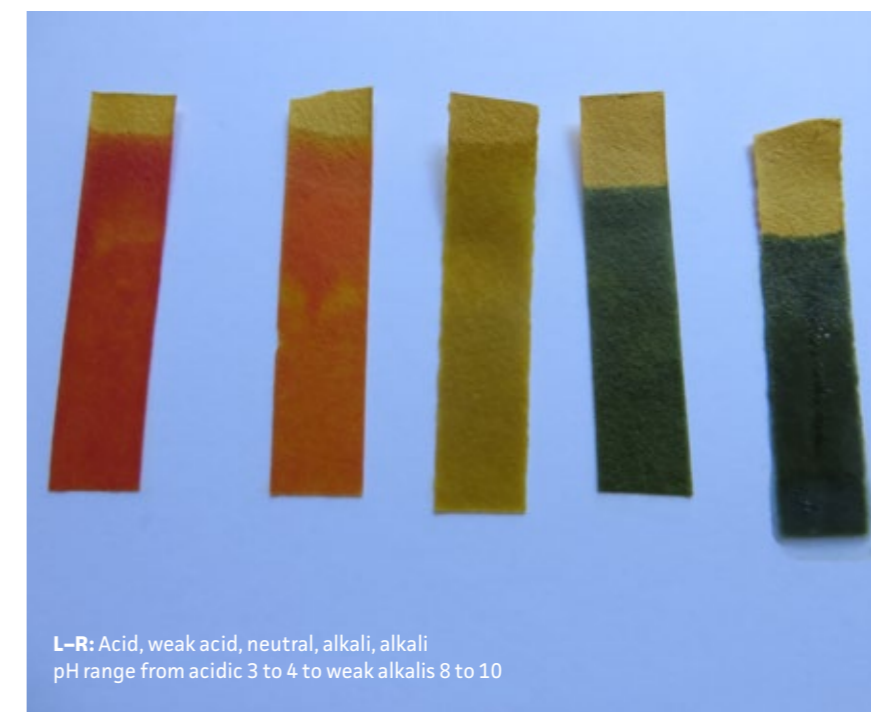

Sample	Test paper colour	Acid, neutral or alkali	Pure water (yes or no)
A			
B			
C			
D			

Activity Sheet 6c ★ **Concept cartoon for melting ice**

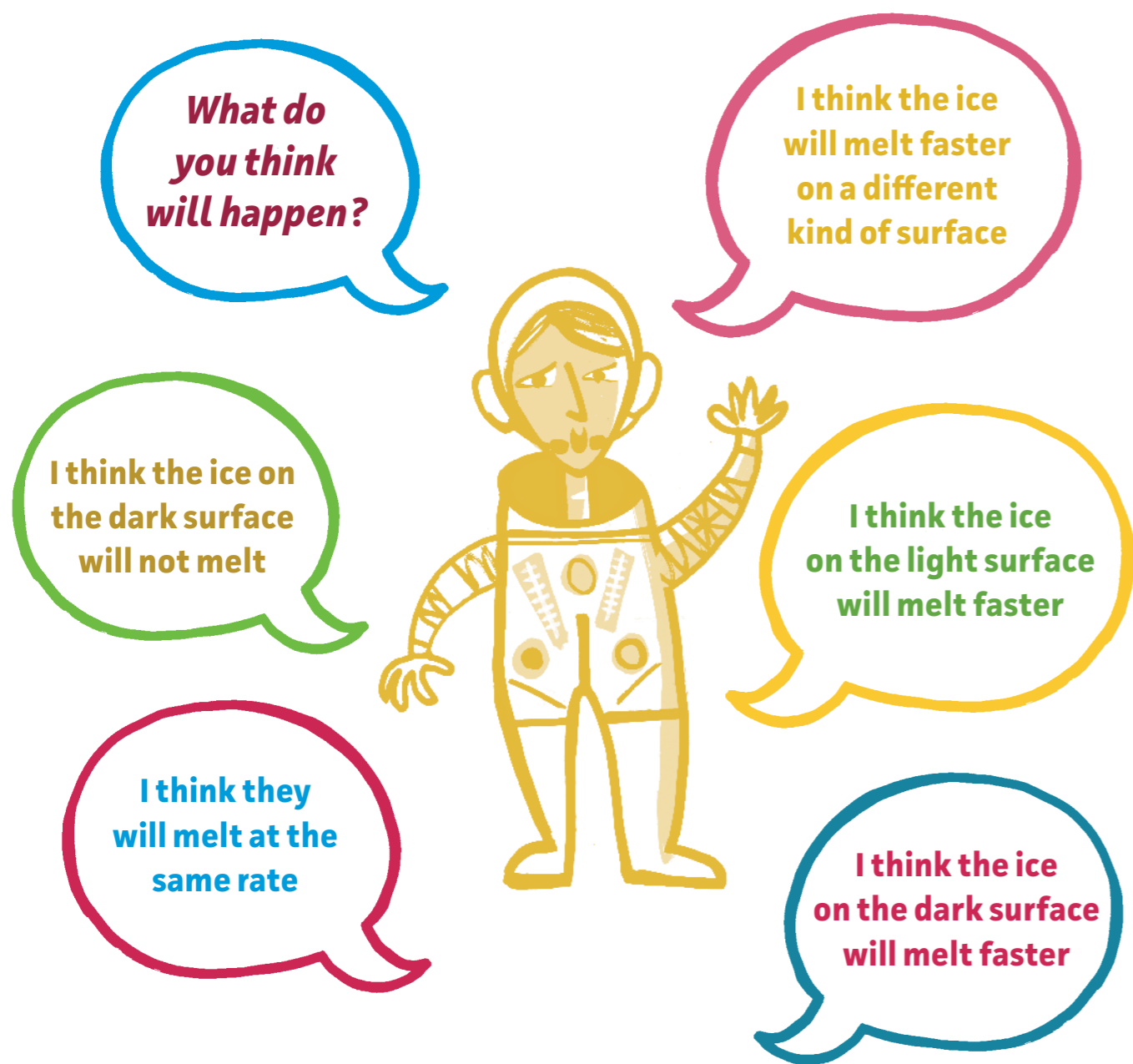

OBJECTIVES

- ★ Use the keyboard to move a LUVMI rover to observe different rock types
- ★ Debug a Scratch program to enable the rover to move around
- ★ Complete a Scratch program to move a LUVMI rover across the whole image to look for water
- ★ Discover the best route for the LUVMI rover when searching for ice in six different locations

LIVING & EXPLORING
7 Finding water with the LUVMI Rover
A coding challenge

LUVMI – Lunar Volatile Mobile Instrumentation – is a wheeled lunar rover weighing 40kg being developed to explore the polar regions of the Moon. It will drive to areas of permanent shadow where sunlight doesn't reach and where temperatures are extremely low. If water exists on the Moon, it might be found in the form of water ice on, or under, the lunar surface.

★ **INTRODUCTION**

Scratch is a block-programming tool commonly used in primary schools. The web-based version requires Flash player to be installed or enabled.

Children will need to have a basic understanding of Scratch before carrying out these activities. Guides and online tutorials are available through <https://scratch.mit.edu/help/>

The first Scratch program involves children using the cursor keys on the keyboard to move an image of the LUVMI rover around the background image of the south pole of the Moon. They must move the rover over different types of rock on the surface.

The second Scratch program requires children to add two pieces of missing code in to the program to enable the rover to move in the same way as it did in the first activity.

The third Scratch exercise requires children to complete some code to enable the rover to explore the whole image to find four water samples which are randomly placed on the background image.

The final Scratch exercise involves children driving the LUVMI rover to look in the shadows behind six different rocks. They will time themselves taking different routes to work out which route is most efficient to visit all six locations.

★ **ACTIVITIES**

The following four exercises use Scratch, a web-based block programming tool, to program the LUVMI rover to explore the south pole of the Moon.

★ **ACTIVITY 1:**
LUVMI EXPLORING THE LUNAR SURFACE

The first activity involves children using the cursor keys, up, down, left and right, to move a Sprite of the LUVMI rover around the south pole of the Moon. The rover will be taking images of different rocks on the Moon. Once the rover passes over a rock, the rock type will be shown and then it will disappear from the image.

Children should follow this link <https://scratch.mit.edu/projects/252041044/> and click on the green flag to start.

There are four different rock samples:

Orange glass. This comes from lava fountains on the Moon, when it still had active volcanoes.

Pyroxene/olivine. Common silicate materials found on the Moon.

Anorthosite. Lighter coloured Moon rock that is the oldest type on the Moon. Formed when feldspar crystallised and floated to the top of the hot magma ocean soon after the Moon formed.

Breccia. Smaller parts of rock that have been fused together during an impact of a large meteorite.

The breccia sample is very dark and so may not be immediately obvious when looking at the image.

Real samples of these types of material can be borrowed as part of the Science Technology Facilities Council (STFC) Borrow the Moon scheme.

★ **ACTIVITY 2:**
LUVMI EXPLORING THE LUNAR SURFACE 2

This activity is the same as Activity 1 but two of the commands have been removed from the code for the LUVMI Sprite: the right arrow and the down arrow commands have been removed. Follow this link to start <https://scratch.mit.edu/projects/252063317/>.

Children should click the green flag to try the activity and discover how it is different to Activity 1. They should then click "See Inside" and add two pieces of code for the LUVMI Sprite so that it matches the code for Activity 1.

They will need to use code from the Event and Motion tabs to do this.

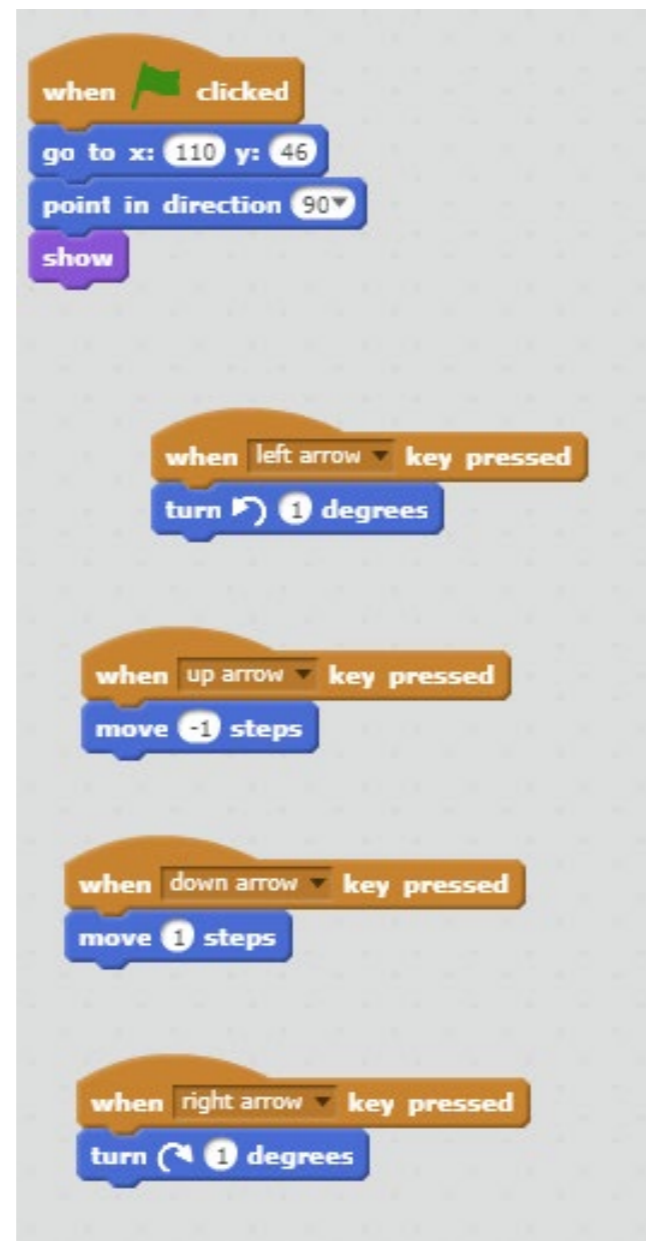

★ **ACTIVITY 3:**
LUVMI FINDING WATER ON THE MOON

In this activity, children must write code for the rover to ensure that it covers the whole image and finds four water samples. Water could exist on the Moon in the form of ice, in permanently shadowed regions in craters, or behind rocks.

Rovers will often be programmed to move around a surface autonomously, so that no real-time external intervention from Mission Control is needed for them to complete certain tasks. This is because the rover cannot always be in contact with a control centre and there is also a time delay between sending the code from Earth and it being received by the rover.

The children should first open the Scratch program <https://scratch.mit.edu/projects/252064564/>, read the instructions and click the green flag to run the program. Some of them will find that they have discovered one or two water samples when they run the program and some will find none. This is because the location of the water samples is randomly generated each time you run the code. They should click "See inside" so that they can edit the code. They will need to edit the code for the LUVMI Sprite.

The code has been started, so that the rover moves part-way in one direction across the background image and then turns.



Children must complete the code so after pressing the green flag, the LUVMI rover will move across the whole surface. This could be completed in different ways – for example, the rover could move from right to left in rows across the surface (in much the same way as you might mow a lawn), or the rover could move in a spiral from outside to inside.

The only rule is that the rover should move in increments of only 1 or -1 steps. This is to show that the rover will only be able to move slowly across the surface using its batteries, which must be charged using its solar panels when it is in sunlight.

This is one possible solution which uses the “lawn mowing” method <https://scratch.mit.edu/projects/252579751/>. Finding code that works will require some trial and error and children may find ways of simplifying their code once they have created it. In the example solution, the simplification is provided by looping through the same code three times.

```

show
repeat 3
  point in direction 90
  repeat 375
    move -1 steps
  repeat 90
    turn 1 degrees
  repeat 60
    move -1 steps
  point in direction 90
  repeat 375
    move 1 steps
  repeat 90
    turn -1 degrees
  repeat 60
    move 1 steps
  
```

★ **ACTIVITY 4:**
LUVMI SEARCHING IN THE SHADOWS

In this activity, children will drive the LUVMI rover, using the cursor keys, to look for ice in the shadows behind rocks. The link to the Scratch model is <https://scratch.mit.edu/projects/253626690>. Water ice may exist in these shadows, where the temperature remains very low.

They should aim to visit all six rocks in the shortest time possible. As soon as they click the green flag, a timer will start, shown in a speech bubble next to the rover. When they pass over a rock, a message will be displayed to show whether they have found water, and then the Sprite will disappear. Once they have visited all the rocks the timer will stop to show them how long it took them.

The rocks are numbered 1 to 6 but they should not necessarily visit them in this order. They need to find the order that they think gives the fastest route. Children may be able to see certain routes that they could discount immediately (e.g. 1,3,4,6,5,2), but there are a few routes that they will need to try out. In total, there are $6 \times 5 \times 4 \times 3 \times 2 \times 1 = 720$ possible routes, so they can't try them all but they could choose around 5 to investigate and then split it between groups to test out.

A couple of the faster routes are 6,3,4,2,5,1 and 6,1,2,5,4,3.

Finding the shortest route between a number of points is a common mathematical problem, typically known as The Travelling Salesman Problem. LUVMI will need to make calculations to find the best route, in order to maximise the number of sites it can visit and to conserve battery power.

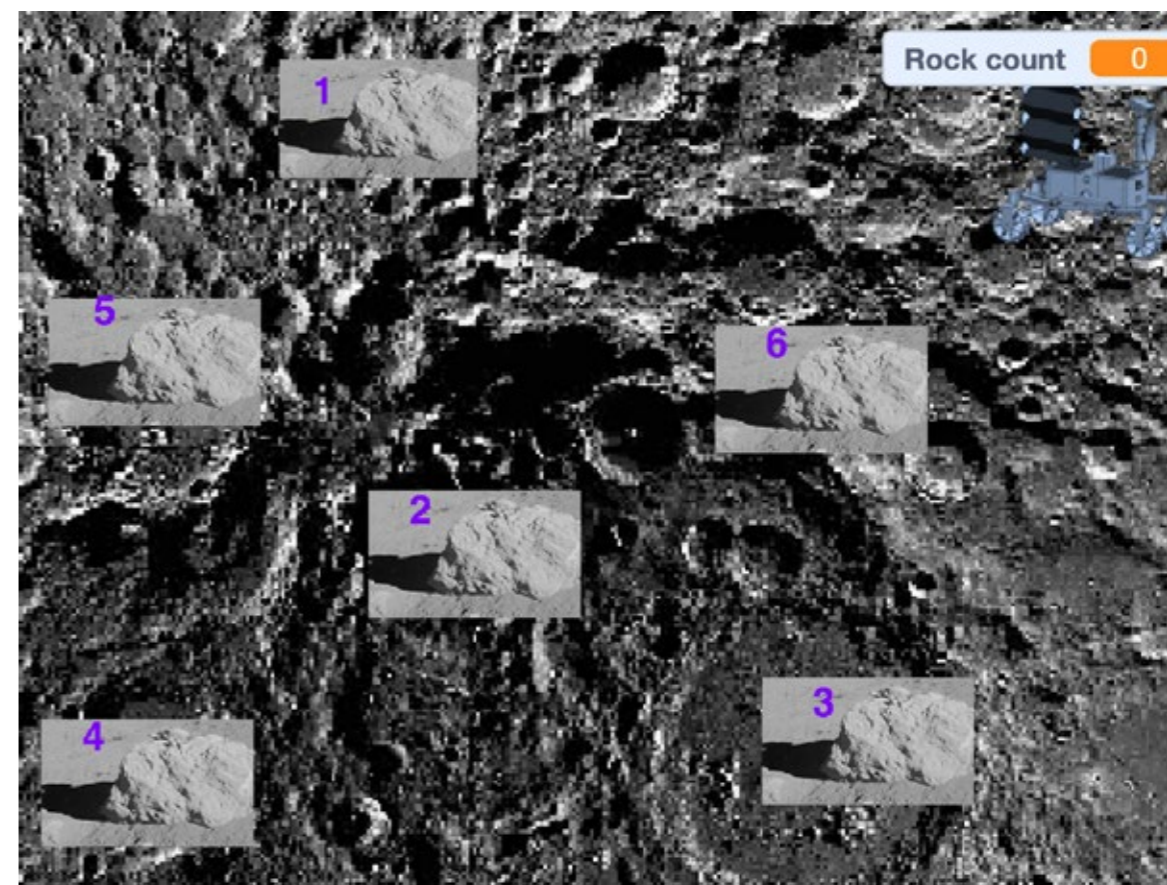

LIVING & EXPLORING

8 Moon Dust

OBJECTIVES

- ★ The surface of the Moon is dusty
- ★ The lunar regolith is produced by meteorites crashing into rocks on the Moon's surface
- ★ To find a method to reduce solids to powder

Lunar dust is fine like a powder but it is so sharp it can cut like glass. It is formed when meteorites crash onto the Moon's surface, heating and smashing rocks and dirt which contain silica and metals such as iron. The absence of air and water to smooth rough edges means that the tiny grains are sharp and jagged and cling to everything. Dust particles remain untouched unless an impact occurs. The dust is electrically charged and sticks to any surface on contact. There is some evidence that the dust particles are constantly leaping up and falling back to the Moon's surface. The soil becomes increasingly compacted beneath the top layer of regolith.

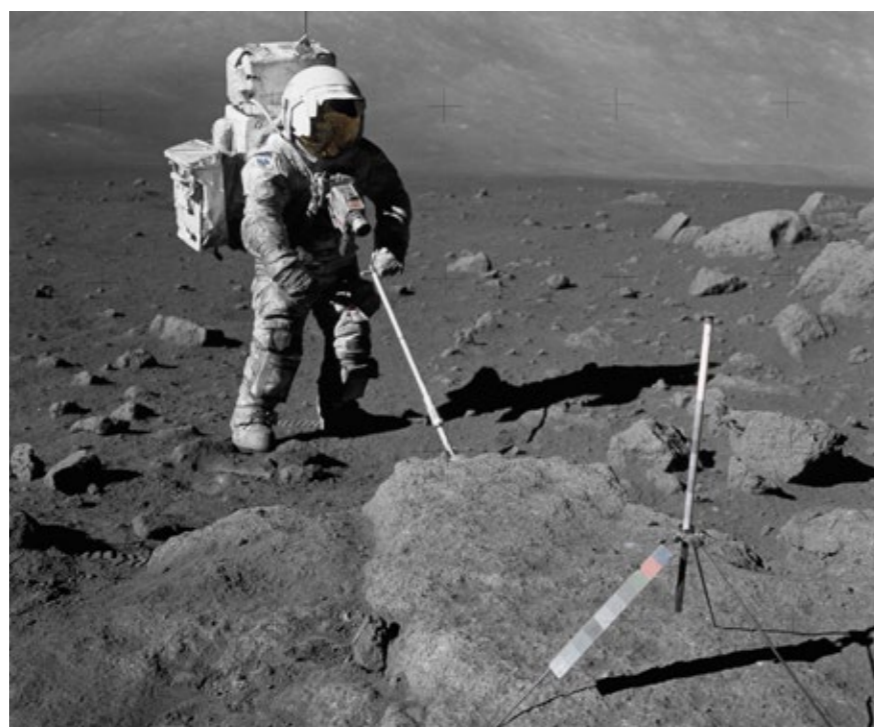

★ ACTIVITY

In these activities, the children investigate powdery surfaces and experiment with compacting surfaces using a variety of objects to produce impressions, try different methods for reducing the size of solids and determine the hardness of solids through drop and compression tests.

★ INTRODUCTION

Show this video clip – https://youtu.be/jBfxAQrb3_M – or an image of an astronaut's footprint on the Moon's surface from Activity sheet 7a. Explain that the Moon is covered in dust, caused by impacts of asteroids and meteorites with lunar rocks, breaking them into tiny pieces; due to the absence of rain, wind or movement on the surface of the Moon, the dust settles and imprints remain unchanged for millions of years. Further impacts reduce small pieces of rock to even smaller particles and finally dust.

AGES 5 TO 7: MAKING AN IMPRESSION

★ RESOURCES

- Shallow box or 'tidy tray'
- Flour
- Sand
- Rock salt
- Pebbles
- Objects for pressing into the lunar surface, eg Lego blocks
- Caster sugar – optional
- Granulated sugar – optional

★ FEELY BOX – OPTIONAL ACTIVITY

- Cardboard box
- Cling film
- Rubber gloves
- Sticky tape
- Small fan

★ ADVANCE PREPARATION

Role badges for lunar geologist, Appendix 1

Prepare a lunar surface in a tray or shallow box. Half fill the tray with sand and cover with a layer of rock salt. Finally, coat the surface with a thin layer of flour.

A lunar 'glove' box could be made using a cardboard box with two holes cut into the side and containing a layer of sand with a topping of rock salt and then flour. Insert a pair of rubber gloves into the holes and carefully secure each glove to the edges of the holes with sticky tape. Place various shapes and stones as 'Moon rocks' inside the box. Seal the top with cling film.

Explain that the children are going to press different objects and shapes into the pretend lunar surface, observing and describing the imprint produced each time. They can try pressing more gently or with greater force. They might investigate changing the surface coating by adding fine sand, sugar or salt.



Explain to the children how real rock and soil samples brought back from the Moon are protected from water or air. Scientists handle the samples using gloves inside a protective box. The children, acting as **lunar geologists**, use the glove box to handle the rocks and investigate the dusty lunar surface by making imprints using the various objects and shapes. Remind the children that there is no wind on the Moon, but here on Earth, the wind can blow away particles of dust, sand or soil and imprints can disappear over time. If a small fan is placed in the box, the children could try gently blowing across imprints made in the sand or flour surface.

AGES 7 TO 9: MAKING POWDERS

★ RESOURCES

- Paper cups with lids
- Sugar cubes
- Marbles
- Small stones
- Rolling pins or cylinders



Image shows damage to sugar cube after shaking with marbles in a cup

Explain to the children that they have been provided with sugar cubes to represent the rocks on the surface of the Moon. *Can they suggest ways of reducing the size of the sugar cubes to produce finer particles?* The groups discuss their ideas and use a whiteboard or activity planning sheet to draw or list their ideas. Discuss the suggestions. Provide suitable resources for the groups to test the effectiveness of their methods. Methods might include crushing, squashing, rolling, shaking, rubbing or dropping solids. Paper cups with lids allow a safe way of shaking the cubes. They could add another object such as a marble, small stone or other hard object to the cup to collide with the sugar cube. *What will they keep the same to make the test fair? How will they measure the effectiveness of the methods?* They might suggest shaking the cubes for the same length of time or shaking the cup the same number of times. They might compare the change in size of the sugar cubes or the volume or weight of sugar particles produced each time. The unbroken sugar cubes can be separated from the granules by sieving. The volume of granules could be measured using a measuring cylinder.

AGES 9 TO 11: IMPACT TESTS BY DROPPING 'METEORITES' DOWN A TUBE

★ RESOURCES

- Stones or pebbles
- Tray with thin layer of sand
- Tube
- Sugar cubes
- Metre stick
- Measuring cylinder

Explain that the children are going to model the impact on Moon rocks of meteorites landing on the lunar surface. Sugar cubes or other brittle objects, placed in a tray containing a thin layer of sand, will simulate lunar rocks. *Can the children think of a way to model the impact from meteorites? How could they measure the damage caused?* How might they compare the effectiveness of the objects dropped?

Allow time for the groups to discuss their ideas. Suggestions might include dropping objects such as stones onto the sugar cubes. For safety, use a tube through which to direct objects such as stones onto the sugar cubes. The children observe how the height of drop or mass of the object dropped affects the size and shape of the sugar cube, after impact.



Image shows damaged sugar cube after impact by pebble 'meteorite'

★ PLENARY

Discuss the results with the groups.

Which objects caused the greatest damage to the sugar cube lunar rocks? Was there a link between height of drop or weight or size of meteorite and damage caused?

Remind the children that bombardment of rocks by meteorites crashing onto the surface of the Moon over millions of years has caused the surface to become dusty. To demonstrate this, half fill two trays with sand and add a fine coating of flour to each. One will represent the soil on Earth, the other the lunar surface. Make a footprint in each. Use a fan to blow across the footprint in the first tray, to model the erosion of the surface by wind on Earth and encourage the children to observe the changes. The footprint on the lunar surface remains unaffected due to the lack of atmosphere, unless damaged by meteorite bombardment.

Finally, watch the 17-second video animation by NASA Ames LADEE mission of a meteorite impact: <https://youtu.be/mDNXAicVHZA>

★ EXTENSION

The children might extend these investigations by changing the angle of impact of a 'meteorite' or by testing different brittle mock lunar rocks, such as chalk, crackers or meringues. They could change the size, shape or density of the 'meteorites' dropped and measure the effect.

Activity Sheet 8a ★ Moon Dust

ASTRONAUT FOOTPRINT ON THE MOON

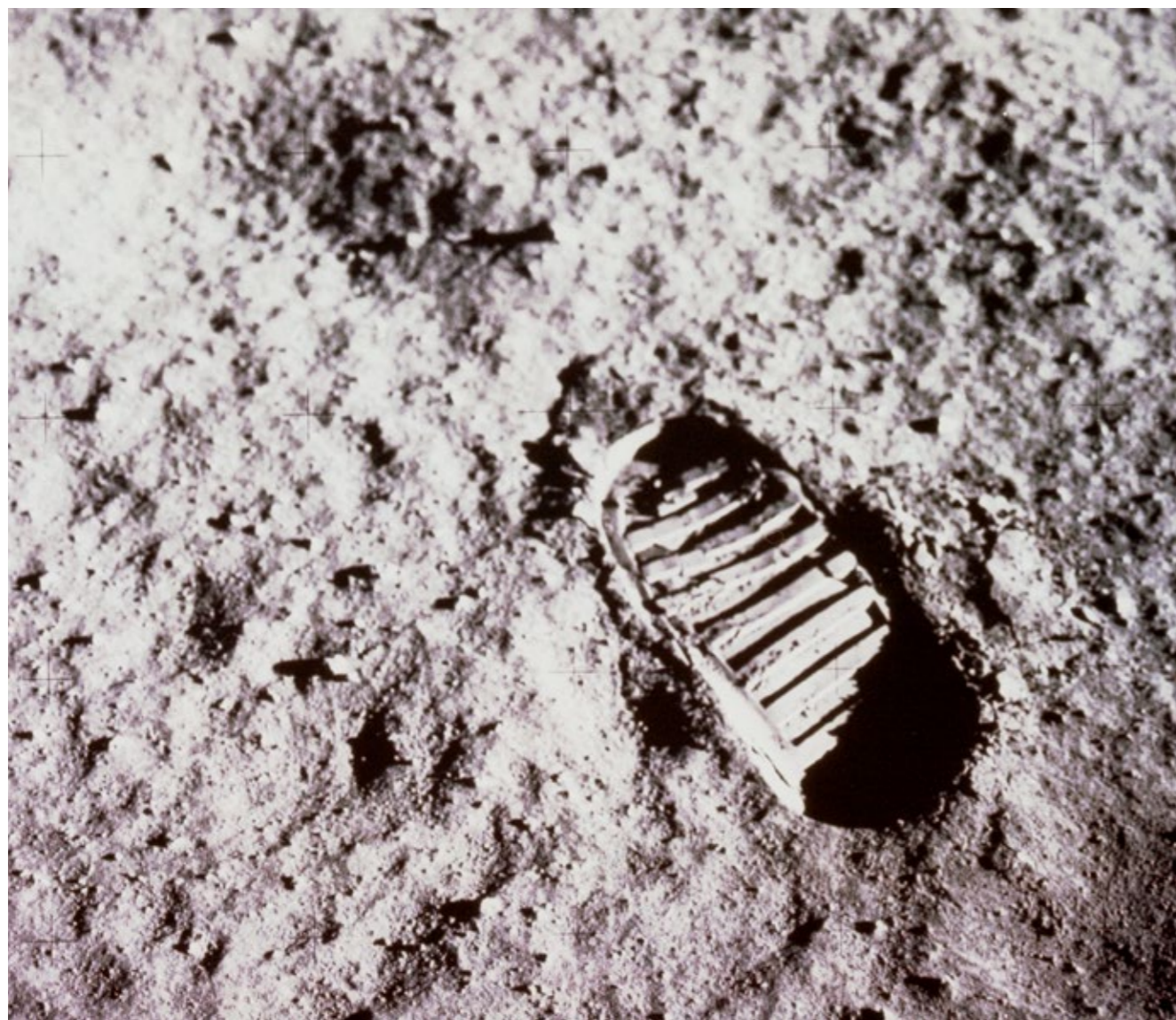

Image courtesy of NASA

LIVING & EXPLORING 9 The Power of Attraction – A Sticky Question

"Moonlight on your skin
Moon dust in your lungs
Stars in your eyes
You are a child of the cosmos
And ruler of the skies" – lyrics by Emma Johnston



Apollo 17 astronauts noticed a 'horizontal glow', a slim bright crescent just above the lunar surface at the sharp line where lunar day meets lunar night. Scientists think that this may be caused by dust particles scattering light. A recent study showed that dust particles can generate unexpectedly large electrical or 'electrostatic' charges and that particles of similar charge can repel each other with such force that they can be lifted off the lunar surface.

In this activity, the children investigate ways of creating electrostatic charge using a variety of materials and then test whether electrostatic charge can lift particles from a surface.

OBJECTIVES

- ★ When different materials are rubbed, an electrostatic charge can be produced
- ★ Materials with a similar charge will repel one another whilst opposite charges attract
- ★ Dust particles on the Moon can become electrostatically charged

RESOURCES FOR A CIRCUS OF ACTIVITIES

- ★ Salt and pepper
- ★ Paper plate
- ★ Plastic spoon
- ★ Woollen, silk, towelling cloths
- ★ Polyester material
- ★ Balloons
- ★ Empty cans
- ★ 'Foam' polystyrene plates or bowls x 2
- ★ Length of thin PVC pipe or plastic ruler x 8
- ★ Thin plastic bags cut into loops
- ★ Paper clip
- ★ Cotton thread
- ★ Tray or container to catch water
- ★ Cup with small hole in base
- ★ Shoebox lid
- ★ Cellophane or clear plastic
- ★ Matchstick
- ★ Pencil
- ★ Glass or cup (transparent)

★ **ADVANCE PREPARATION**

Most of the activities can be prepared by reading the instruction cards on Activity sheet 9b

Role badges for physicist, Appendix 1

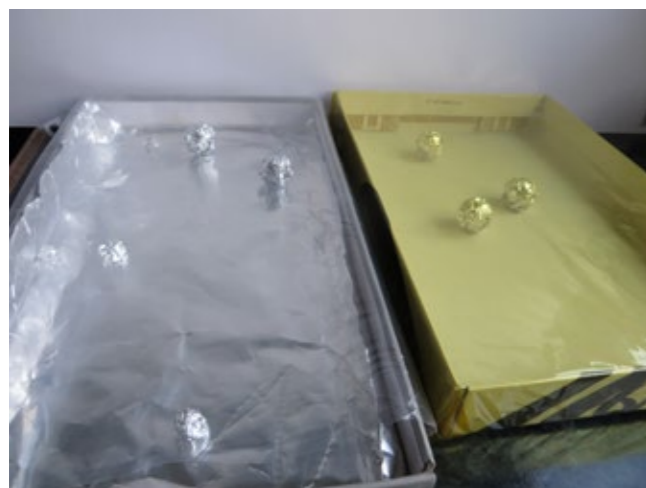

The image shows examples of one of the activities, 'Dancing Balls'. Cover small expanded polystyrene spheres with foil. Place the balls in a shoebox lid. Cover the lid tightly with cellophane, a clear plastic bag or polypocket. Rubbing the plastic with your hand produces a charge on the plastic. Moving a finger close to the balls will cause them to move about.

Provide a copy of Activity sheet 8a for each group or download onto whiteboard. Set up a variety of activities around the classroom. Provide instructions for each activity using Activity sheet 9b.

★ **INTRODUCTION**

Begin the lesson with a demonstration of producing an electrostatic charge. Ask for a volunteer and rub a balloon on the volunteer's head. Move the balloon away and observe hairs on the head standing up, being repelled by other hairs. Move the charged balloon above a pencil balanced on a can and watch the pencil rotate

to the left and right as the balloon is moved clockwise or anticlockwise.

Show the children a short video of an electrical storm and explain that electricity can build up in the clouds and then finds its way to Earth causing a dramatic flash of lightning:

<https://youtu.be/1gZZgzX3JEY>

or play the following clip from BBC's Terrific Scientific explaining lightning strikes:

http://www.bbc.co.uk/guides/zqw3fcw?intc_type=singletheme&intc_location=terrificscientific&intc_campaign=power&intc_linkname=guide_lightning_contentcard2

Explain that materials can become electrically charged. These charges can be positive or negative. Materials of similar charge repel each other, whilst opposite charges attract. Astronauts have noticed a glow above the surface of the Moon. Scientists believe that this is produced by dust particles on the lunar surface becoming charged and some repelling one another, causing the dust to rise up from the surface, as shown in the image on Activity sheet 8a.

Today, several challenges have been set up in the classroom and the children are to try the activities and note what is happening in each one. The groups may like to make a record of the activities either through drawings or photographs.

★ **PLENARY**

The children share their observations with the class when all groups have had the opportunity to try the various challenges. *Can they describe and explain what they observed?*

★ **EXTENSION**

The children could research other examples of static electricity and demonstrate their findings to the class or other year groups.

They could also investigate using everyday materials from the Triboelectric list, provided in Teacher information, to rub and charge a length of thin PVC pipe. Test by holding the pipe near to a polystyrene sphere. *Which works best? Could they devise their own list?*

★ **TEACHER INFORMATION**

When two materials are in contact, electrons may move from one material to the other, leaving an excess positive charge on one material and an equal negative charge on the other. When certain pairs of unlike materials, such as wool and plastic, rub together, one material passes some of its electrons to the other. The separation of charge can create an electric field. Here on Earth, the air around us and the clothes we wear are relatively humid and conduct electricity, so any charged particles can travel to the ground. However, on the Moon there is no atmosphere its soil is drier than any desert on Earth and is a good insulator. Astronaut suits and spacecraft such as rovers are made from a variety of materials and these materials are very unlike one another. Electrons collect on the wheels of rovers as they travel and on the boots of astronauts as they walk. There is no pathway to the ground for the electrons to follow and consequently, large charges can build up. Future lunar missions would use equipment to excavate the lunar surface and dust could build up possibly dangerous electrostatic fields.

A list of some common materials is shown below. It is called the **Triboelectric Series**. Under ideal conditions, if two materials are rubbed together, the one higher on the list should give up electrons and become positively charged.

- your hand
- glass
- your hair
- nylon
- wool
- fur
- silk
- paper
- cotton
- hard rubber
- polyester
- polyvinylchloride plastic



Activity Sheet 9a ★ The power of attraction

DUST PARTICLES HOVERING ABOVE THE MOON (NASA)

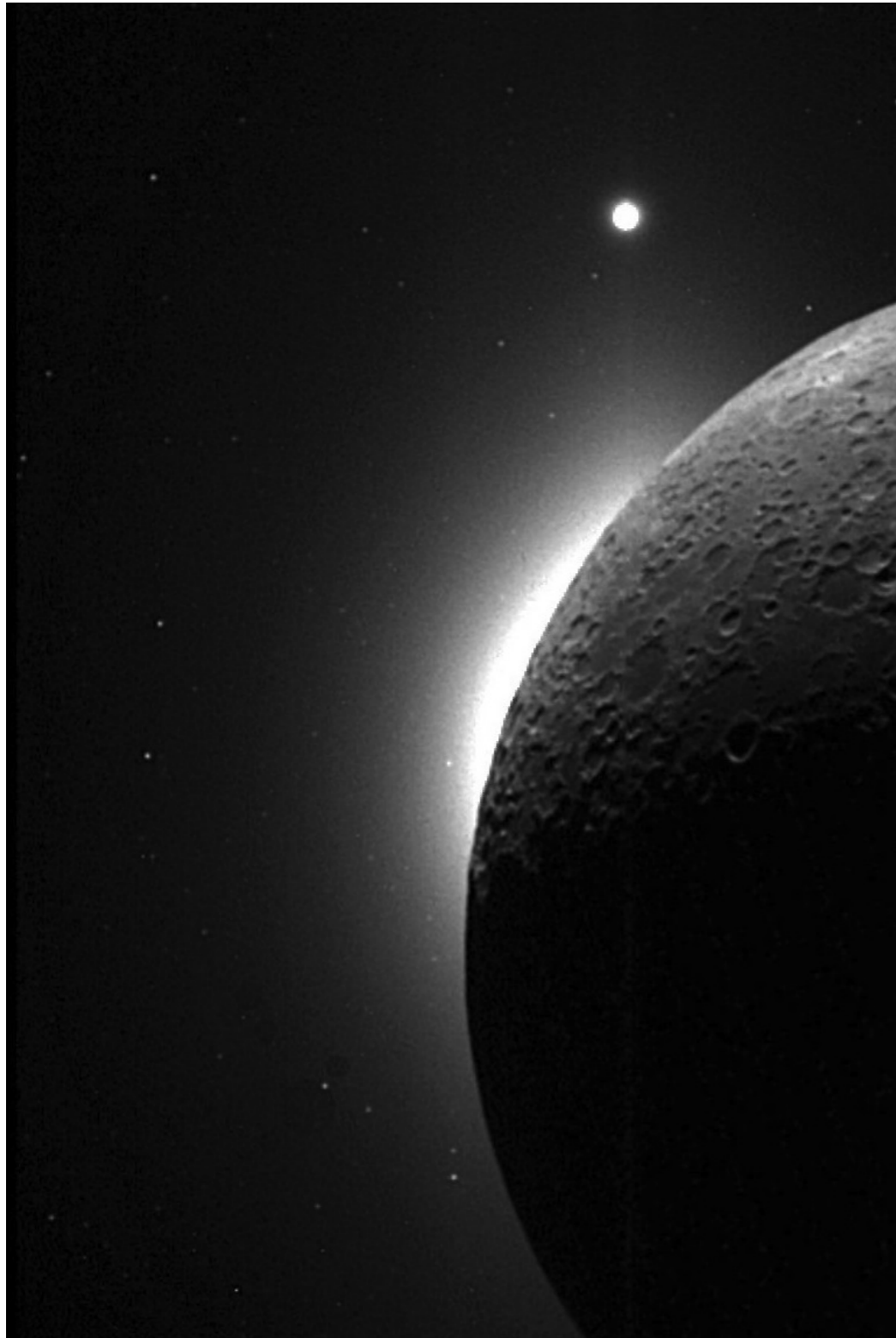

Activity Sheet 9b ★ The power of attraction (Instructions for each activity)

Jumping plates

Place one expanded polystyrene plate upside down on the table
Rub the second plate with the cloth
Place the rubbed plate on top of the other plate and let go
Describe what happens
Can you explain?

Balloons

Rub the pipe with the cloth
Suspend two balloons by their strings near but not touching one another
Hold the pipe near one balloon
Now hold it between the balloons
Move the pipe left and right without touching the balloons
What happens?
Can you explain?



Moving cans

Lay the empty can on its side on the table
Rub the PVC pipe with the cloth
Hold the pipe over one side of the can and then the other
What is happening?
Can you explain?



Match suspended in a jar

Rub the PVC pipe with the cloth
Hold the pipe at one side of the glass
Hold the pipe at the other side of the glass
What is happening?
Can you explain?



Salt and pepper

Sprinkle some salt and pepper onto the plate
 Rub the plastic spoon with the woollen cloth
 Hold the spoon close above the salt and pepper
 What happens?
 Can you explain?



Polystyrene spheres

Place a couple of polystyrene spheres on the tray
 Rub the pipe with the cloth
 Move the pipe near to but not touching the spheres
 What do you notice?
 Can you explain?

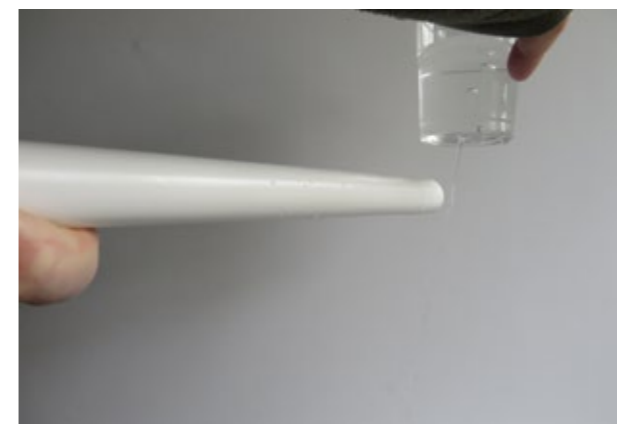

Bend water

Rub the pipe with the cloth
 Fill the cup with water
 Hold the cup over the tray
 See the water flowing from the small hole in the bottom of the cup
 Hold the pipe near the stream of water coming from the cup
 What happens?
 Can you explain?



Bubbles

Pour a small amount of bubble mixture onto the tray
 Use the straw to blow a bubble in the bubble mixture on the tray
 Rub the PVC pipe with the cloth
 Hold the pipe over the bubble
 Slowly move the pipe towards one side of the sheet and then back
 Blow another bubble and hold the pipe between the bubbles
 What happens?
 Can you explain?

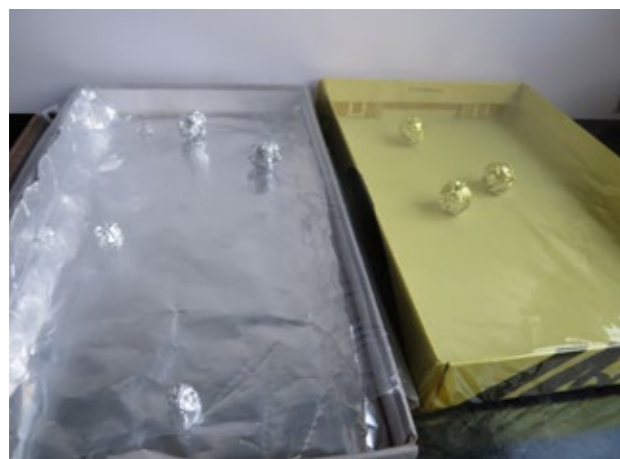

Dancing balls

Rub the plastic sheet gently with your hand
 Put your finger on top of the plastic close to the balls
 What happens?
 Can you explain?

Floating bags

Rub the pipe and the plastic loop with the cloth
 Throw the plastic into the air
 Bring the pipe under the plastic without touching it
 Can you keep the plastic in the air by waving the pipe under it but not touching?
 Now investigate different plastics one at a time
 Throw the loops cut from plastic bags into the air
 Can you keep each in the air by holding the pipe under them?
 What is happening?
 Can you explain?

LIVING & EXPLORING 10 Crystal Mountains

OBJECTIVES

- ★ A mixture of dry solids of different sizes may be separated by sieving
- ★ Some solids dissolve in a solvent such as water to produce a solution
- ★ Solids dissolve more quickly in warm water than in cold
- ★ A saturated solution is one in which no more solute can dissolve
- ★ Evaporation can be used to recover a soluble solid from a liquid

RESOURCES PER GROUP OF FOUR

- ★ A set of crystalline solids, eg sugars, table salt, rock salt, Epsom salts
- ★ A set of non-crystalline solids, eg flour, cocoa powder, rice, lentils
- ★ Petri dishes or paper plates
- ★ Magnifying lenses
- ★ Images of named crystalline solids

★ MAKING CRYSTALS

India's Chandrayaan-1 probe found giant mountains of crystals on the Moon, extending to 40km approximately. The discovery provided an insight into the Moon's ancient, crystalline crust. It is suggested that a magma ocean may once have covered the Moon. Heavy iron-bearing minerals are believed to have sunk through the magma to form the Moon's mantle, while lighter iron-poor minerals called plagioclases could have crystallised and floated to the surface. Ruby-like gemstones called spinels have been discovered on the far side of the Moon and also in the Sinus Aestuum, a big plain that most people recognise as the nose of the man in the Moon on the side facing Earth! A ruby or spinel was found in King Henry V's battle helmet and now forms part of the State Crown of England!



AUTHOR
PublicDomainPictures

★ ACTIVITY

In these activities, the children observe and experience a variety of crystalline solids, separate solids by sieving and investigate conditions for growing crystals of different sizes.

★ ADVANCE PREPARATION

- Role badges for space scientist or crystallographer, Appendix 1
- Image of the Moon on the whiteboard showing the location of the crystalline solids
- Place a teaspoon of each solid onto separate plates or containers

For the demonstration:

- Transparent cup of sunflower oil or similar
- Small stones, grit, caster sugar
- Teaspoon

★ INTRODUCTION

Introduce the session by providing each group with a selection of crystalline and non-crystalline solids. The children observe the solids closely using magnifying lenses*.

Can they describe the solids? What is the difference between them? What is a crystal? What shape are they? Where would you find crystals at home?

Crystals come in many shapes and sizes, often too small to see without a magnifying glass.

Display a large map of the lunar surface (see image on Activity sheet 9c) showing the location of the area where crystalline solids were identified and describe how, millions of years ago, the crystal solids are thought to have floated up through an ocean of magma to the surface of the Moon. Demonstrate this by adding a spoonful of different sized solids, eg gravel, grit and sugars to a transparent plastic cup or jar of sunflower oil and watching the settling of the heavier particles to the bottom of the cup and the smaller solids held in suspension.

Explain that each group has been provided with a set of unidentified solids, some crystalline, and they are to use their observational skills to identify each one by matching it with the images on the chart.

***Health & Safety:** remind the children not to eat or put any of the solids into their mouths.

The following activities and investigations are then followed, depending upon the year group.

Ages 5 to 7

RESOURCES PER GROUP OF FOUR

- ★ Sieve
- ★ Tea strainer
- ★ Tweezers
- ★ Colander
- ★ Teaspoon

★ ADVANCE PREPARATION

In a tidy tray or shallow box, prepare a lunar surface using a base layer of sand. Place a fine layer of rock salt over the sand layer. Add a final upper layer of flour.

Explain that the mock lunar soil trays have crystalline solids concealed under the surface. The groups 'explore' the lunar surface sample and attempt to locate and separate crystalline solids concealed within.

*How might they separate the crystalline solids?
What equipment will they need?*

The groups suggest and test their ideas, selecting appropriate equipment.

★ PLENARY

Did they manage to find and separate the crystalline solids? What method did they use? Which equipment was best for the job?

Finally, enjoy reading a story such as 'Papa, Please Get the Moon for Me' by Eric Carle (available on YouTube as a short film).

Lower KS2

In this activity, the children produce crystalline solids by first dissolving in water crystalline solids such as salt, sugar or Epsom salts to form saturated solutions and then evaporating the water from the solutions. It may take a few days to grow the crystals.

RESOURCES PER GROUP OF FOUR

- ★ Half a cup of one of the following crystalline solids: sugar, salt or Epsom salts
- ★ Teaspoon
- ★ String or pipe cleaner
- ★ Plastic or thin wire thread
- ★ Pencil or lolly stick
- ★ Transparent cups x 3
- ★ Magnifying lens
- ★ Food colouring – optional
- ★ Warm water

The children fill a cup with warm water and stir in a teaspoon of the crystalline solid. Stir until the solid has dissolved. They should keep adding more until no more will dissolve and some crystals remain at the bottom of the cup. This is a saturated solution. Cover the cup with a piece of card or paper and leave until crystals have begun to form. Carefully pour only the clear solution into the second cup, ensuring any crystals remain in the first. Tie a piece of string (or a pipe cleaner) to a pencil laid across the top of the second glass and suspend the string in the solution, ensuring it doesn't touch the bottom or sides of the glass; observe for crystal growth over a few days.

To grow a **single** crystal, carefully tip the crystals from the first glass onto a piece of paper. The children closely observe the crystals and choose the largest. This will be the seed crystal. Attach to a piece of *plastic* or *wire* thread and tie the other end to a pencil or lolly stick. Suspend the crystal in the solution but not resting on the bottom of the cup. They might like to add a couple of drops of food colouring at this stage.

Check the growth of the crystal over the next few days and record by drawing or taking photos. If crystals grow on the side of the cup or elsewhere, the single crystal should carefully be removed and the clear solution poured into a third cup and the crystal suspended once more. If left, the single crystal will not grow large and lots of smaller clumps of crystals will be produced.



★ PLENARY

Compare the crystals from each group and discuss similarities and differences.

*Which solid produced the largest crystal or most crystals?
How many days did each take to form? How much solid did they dissolve in water in the first cup?*

★ EXTENSION

Test the effects of reducing the amount of solids initially dissolved, or using cooler or warmer water at the start, or leaving the cups in different locations or putting them in the fridge.



Upper KS2

The children plan and carry out an investigation to grow the largest or most crystals from saturated solutions. They first investigate the amount of sugar, salt or other crystalline solid that can be dissolved in water of different temperatures and record the data in table 1 on Activity sheet 9a. A graph can be drawn from the data of temperature versus mass of solid. Having produced a saturated solution, they decide where and leave the solutions to evaporate. They may choose to divide the solution between several containers or suspend a piece of string in the solution. They measure the crystals produced and record the results in table 2 on Activity sheet 9a. Growth of the crystals could also be recorded in diary format.

★ PLENARY

Photographs taken of the variety of crystals produced by the groups can be shown on the whiteboard. If a visualiser or microscope is available, detailed images of the structures can be seen and discussed. *What did they discover? Which solutions produced the most or largest crystals?* Emphasise the conditions under which crystals are grown determine their size, shape and properties.

★ EXTENSION

Investigate growing crystals from saturated salt solution and vinegar on a sponge base. Place a thin sponge in a polystyrene tray and carefully pour the saturated solution with added vinegar onto the sponge. *How soon do crystals begin to form? Do they differ from those grown in a cup?* Add more saturated solution to the sponge as crystals appear. Try growing a crystal garden by pouring a saturated solution over other surfaces such as brick or rock.

Images show table salt and Epsom salt crystals beginning to form on a sponge.

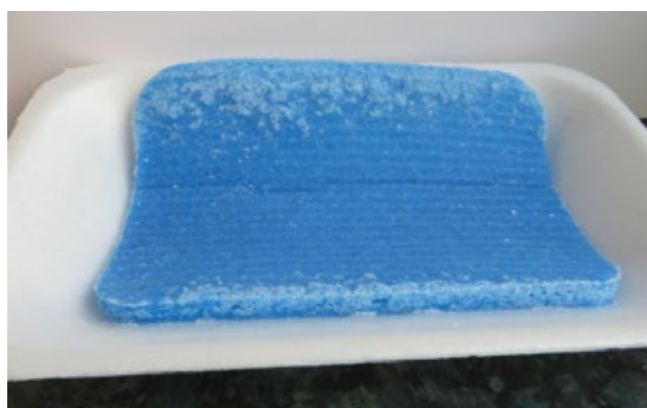
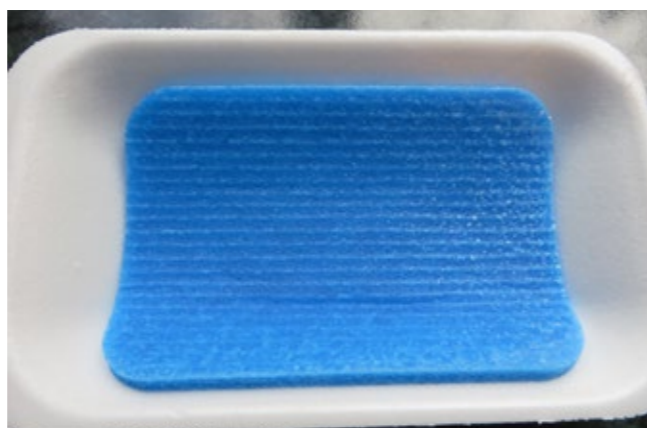

★ TEACHER INFORMATION

Growing crystals here on Earth can be difficult because gravity can affect the formation of delicate crystals. Space scientists grow crystals on the International Space Station under microgravity. Under these conditions, very large and almost perfect crystals can be produced.

Crystals can be seen in gemstones, salt, sugar and medicines. Crystalline solids are atoms and molecules arranged in a repeating pattern and stacked over and over again. Crystals of the same solid are always the same shape. Crystallography uses X-rays to map the position of atoms in a solid and determine its crystalline structure.

Activity Sheet 10a ★ Crystal Mountains

DISSOLVING CRYSTALLINE SOLIDS

Water temperature °C	Mass of solid (teaspoons)

DESCRIBE AND MEASURE CRYSTALS

Name of crystal	Draw	Describe	Measure

Activity Sheet 10b ★ Crystal Mountains

IDENTIFY THE CRYSTAL



Rock salt crystals (Origin NASA educators)



Table salt



Sugar crystals

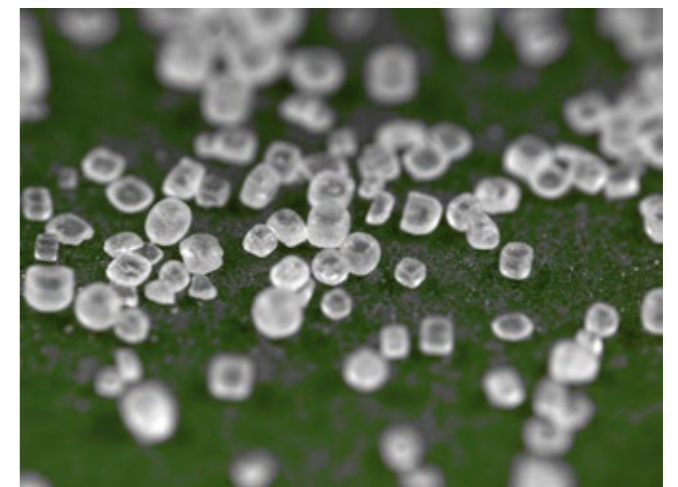

Epsom salts crystals

Images: Creative Commons

Activity Sheet 10c ★ Crystal Mountains

LUNAR IMAGE SHOWING LOCATION OF THE CRYSTAL MOUNTAINS

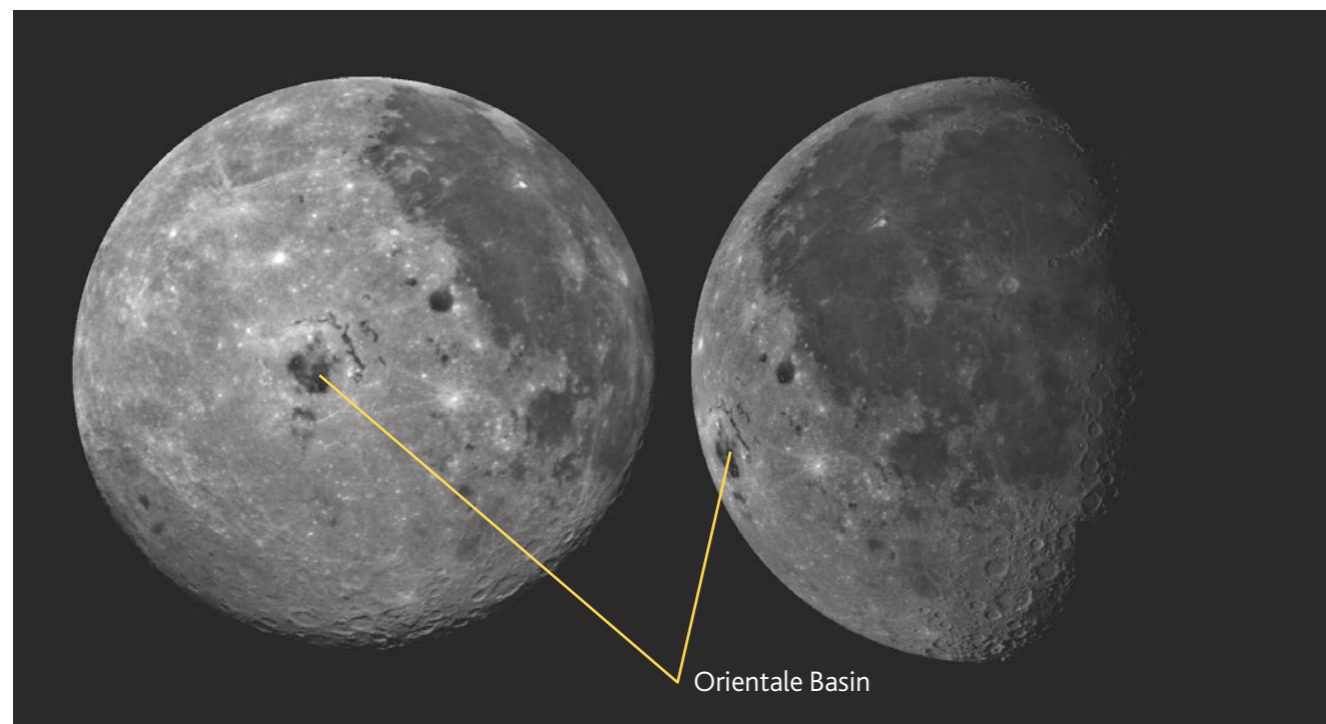

Image NASA

OBJECTIVES

- ★ Compare materials on the basis of colour, texture or shape
- ★ Draw conclusions based on evidence

RESOURCES

AGES 5 TO 7

- ★ Shallow tray or container
- ★ Tools such as spoons, hand drill, scoop, apple corer, plastic straws, clear biro cases
- ★ Rock salt
- ★ Sand
- ★ Fine grit
- ★ Flour
- ★ Magnifying lens

LIVING & EXPLORING 11 Digging the Dirt! Mining on the Moon

As more space missions are announced, the possibility of using the Moon's resources is becoming closer to reality. Rovers are being designed to detect and drill for water, minerals and precious metals. The Moon's resources could be used to build a lunar base, to provide fuel for deeper space exploration or for use on Earth.



NASA hopes that the Resource Prospector rover, with a drill and a tiny internal science laboratory, will be the first mining mission on the lunar surface, whilst the European Space Agency has tested prototypes of lunar rovers to explore the dark polar regions of the Moon.

In these activities, the children take on the role of **lunar geologists**.

Ages 5 to 7: Children test the effectiveness of a variety of tools for taking samples of lunar 'soil', whilst KS2 pupils investigate 'core' samples to determine the depth of layers and their geological make-up and use this information and a lunar map to decide where the samples came from.

★ **ADVANCE PREPARATION**

Role badges for **lunar geologist**, Appendix 1

Place a layer of play dough or plasticine at the bottom of a shallow container. Add a layer of sand and a coating of rock salt, then fine grit and a surface coating of flour.

★ **INTRODUCTION**

Show the children a video of the Apollo 16 rover on the Moon:

<https://www.youtube.com/watch?v=5cKpzp358F4>

or Curiosity rover taking samples or similar:

<https://www.bing.com/videos/search?q=videos+of+moon+rovers+digging&qvt=videos+of+moon+rovers+digging&view=detail&mid=821495219EBD70100032821495219EB-D70100032&&FORM=VDRVRV>

Follow this link to watch a video clip of the LVM1 rover:

<https://www.youtube.com/watch?v=iq-m03c7VF0>

Point out the drill and explain that future missions to the Moon will use rovers, some carrying astronauts, some not, to drill into the surface to collect samples of lunar soil. They will test the samples to detect useful ingredients, such as building materials for a lunar village, ingredients for making fuel or frozen water for drinking.

Show the children the pretend lunar surface and explain that they are going to test a variety of tools to determine which they think is the most effective for digging the soil and collecting samples. *Can the children suggest some tools that would be useful for obtaining samples?* Try to provide as many of the suggested tools as possible, let the children handle them and talk about which ones they think will work best.

After their practical tests, the children may like to sort the tools into effective and not effective groups. They might record their results by drawing. *Which tools worked best and why? Which would they not recommend?*



KS2

OBJECTIVES

- ★ Describe, compare and group materials
- ★ Compare rocks and soils on the basis of properties
- ★ Recognise soils are made from rocks
- ★ Use keys and interpret information
- ★ Draw conclusions based on evidence

RESOURCES PER GROUP OF FOUR

- ★ Tubes containing mock lunar core samples labelled A, B, C
- ★ Teaspoon of each: builder's sand, flour, rock salt, fine grit (eg budgie grit), white gravel, black grit on paper plates
- ★ Activity sheet 11a x 3
- ★ Activity sheet 11b x 1

★ **ADVANCE PREPARATION**

Role badges for lunar geologist, Appendix 1

Using the lunar core recipes in Teacher information, prepare three different samples of 'mock' lunar soil by building up layers of sand, stones or gravel, rock salt, grit and flour in different proportions in plastic tubes with lids. Plastic tubes are easily obtained from the internet at low cost. Three sets should be sufficient for six groups to share. A set per group would be ideal.

Introduce the children to Hannah Sargeant, a geologist (see her biography and photos in Appendix 2) whose job involves using lunar samples to study properties of rocks and soils in order to discover how the Moon's soil, known as regolith, was formed.

In this activity, each sample is laid in the first column of the recording chart and the different layers measured and their colours and particles described. The children record their observations on the chart and finally, use the key on Activity sheet 10b to decide where on the lunar surface each of the samples was taken.

★ **PLENARY**

The image of the Moon surface showing three possible locations where core samples were obtained is displayed on the whiteboard. The groups present their conclusions to the class. *Do all the groups agree?* Reveal which locations match samples A, B and C. Remind the children that in order to fully understand the composition and geology of the lunar regolith, scientists need more information from real lunar samples. These will be obtained in future missions using landers and probes that will drill beneath the lunar surface.

★ **EXTENSION**

The children could be challenged to design a rover and they might research how cranes and scoops work. They could use robotics, pulleys, levers or pneumatics in their prototypes. Conclude by watching a video clip of a challenge to design a lunar 'digger', capable of navigating the lunar surface and digging lunar regolith:

<https://nasaclips.arc.nasa.gov/video/realworld/archive-real-world-moon-dirt>

Activity Sheet 11a ★ Mining on the Moon: Draw the sample

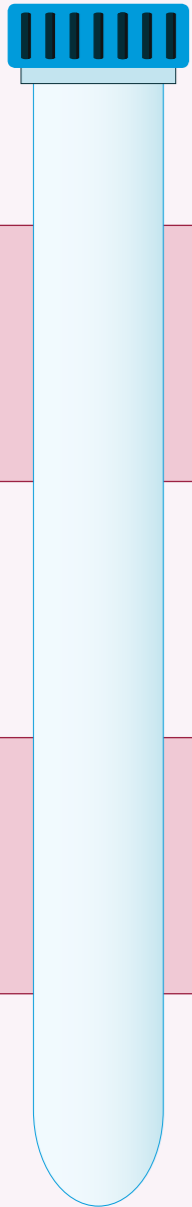
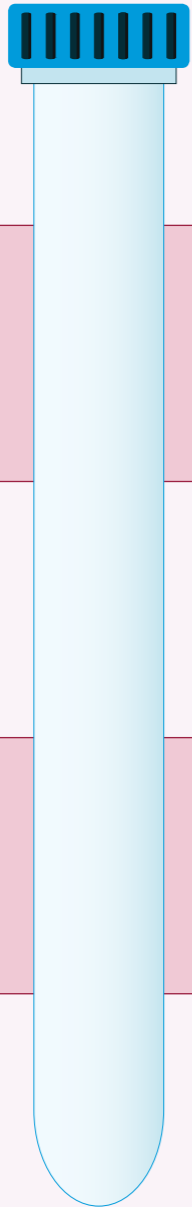
Sample – Measure the layers (cms)	Colour each layer	Describe the colours in each layer	Describe the particles in each layer
			

Activity Sheet 11b ★ Mining on the Moon

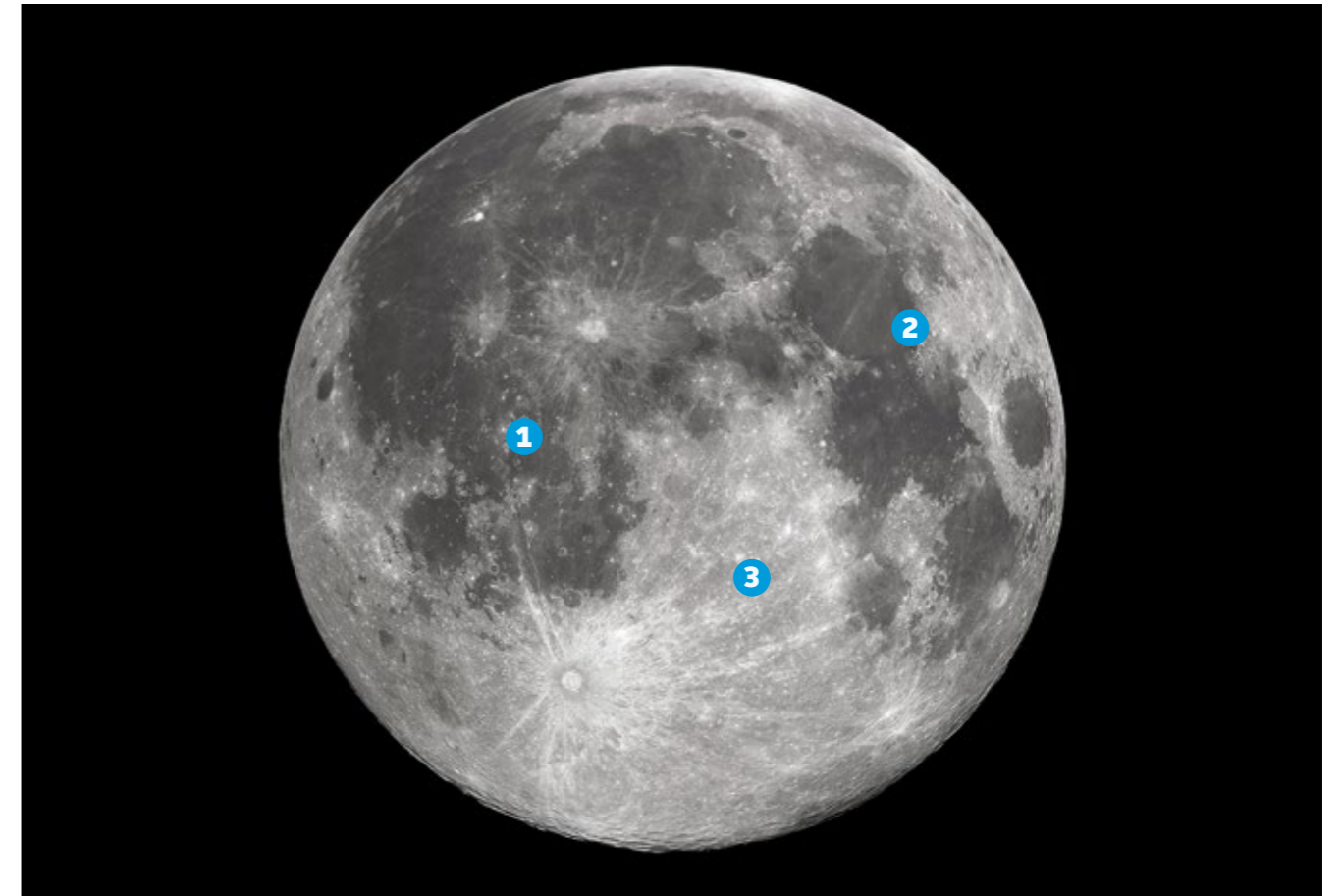

Lunar image shows locations 1, 2 and 3 where core samples were taken and a key giving a description of the regolith content.

1 Apollo 12 landed in the Ocean of Storms or Oceanus Procellarum. Rocks collected were mainly basalt, which is dark-coloured solidified lava; a layer of small-sized crystalline rocky soil with a few red glass beads; a thin layer of greyish grit and a thin top layer of dark grey regolith.

2 Apollo 17 landed in a dark-coloured valley on the edge of the Sea of Serenity. Samples of Moon soil included: a layer of black basalt; white and black breccia; some orange-coloured soil with small orange glassy rocks and a very thick top layer of regolith.

3 Apollo 16 landed in the lunar central highlands. There were lots of craters. Samples of Moon soil included: mostly whitish rocks called anorthosite/ic; smaller crystalline rocks rich in plagioclase with some glassy clear and pinkish beads; a small amount of black basalt and a top coating of greyish grit.

★ **TEACHER INFORMATION**

LUNAR CORE SAMPLES A, B AND C RECIPES

Into clear tubes, place the following ingredients in varying depths, to provide three different samples of mock lunar regolith.

Sample A	Sample B	Sample C
Deep base layer black gravel or sand ('basalt')	Base layer black gravel	Base layer white gravel ('anorthositic' rock)
Layer of whitish gravel or grit	Layer of white gravel mixed with black	Rock salt layer with clear glassy beads plus a few pink glass beads
Layer of rock salt crystals + red glass beads mixed in	Layer of builder's orange sand with a few orange and dark-coloured glass beads	Thin layer black gravel ('basalt')
Fine flour or pale grey layer	Top coating thick layer grit	Top layer fine grey grit
Thin top coating of dark grey grit		

Sample A	Location on Moon	Description of sample
A	1	80% black basalt, 8 to 16% light-coloured particles which are fine grained, some crystalline and some coarse or non-crystalline. The basalts have red-brown glass bits. Beads of glass are scattered in the regolith. Very thin surface layer. Dark grey fine-grained layer covers lighter grey. Apollo 12 landed here.
B	2	The Taurus-Littrow valley floor has large boulders, breccia and basalt underneath. Tiny glass beads from lava ejected from Tycho crater, some orange, make the soil orange but most beads are dark. Some places have light-coloured bits, containing fine grains and rock deposits from avalanches from mountains. The surface regolith is thick. Apollo 17 astronauts drilled for regolith samples here.
C	3	Apollo 16 landed in an old crater west of Mare Nectaris, in the southern central highlands to gather samples from Descartes and Cayley formations. The soil samples here are almost all anorthositic plagioclase. Mainly breccias. Medium-sized grains. The upper regolith is loose. Glassy and crystalline, mainly colourless glass but a few pink bits. Tiny amount of basalt.



Image shows lunar samples A, B, C

Breccia is rock made from broken sharp bits of older sedimentary rocks mixed and melted together. Meteorites crashing into the Moon surface cause rocks to break into smaller pieces and often the heat makes them melt and stick together.

Anorthositic rock is an igneous rock, containing feldspar, the oldest type of rock on the Moon. Plagioclase means the rock easily splits into layers and is hard and crystalline. Often contains calcium.

Scientists need to test their ideas for extracting useful ingredients from lunar soil and for using lunar rovers to

navigate and drill into the lunar regolith before sending astronauts to the Moon. However, there is very little real moon dust available for such tests, so they decided to make a replica or lunar simulant for their investigations. The simulated soil comes in three types based on grain size – fine, medium and coarse.

Teachers can borrow rocks and meteorites from STFC's 'Borrow the Moon' loan scheme, together with an accompanying set of suggested activities developed by STFC and the National Space Academy.

<http://www.stfc.ac.uk/public-engagement/activities-for-schools/borrow-the-moon/>

LIVING & EXPLORING 12 Building Bricks

OBJECTIVES

- ★ Describe and compare different materials
- ★ Forces can change the shape of materials
- ★ Select suitable materials and test for strength and durability

RESOURCES

- ★ Sand
- ★ PVA glue
- ★ Ice-cube trays
- ★ Small disposable cups
- ★ Teaspoons
- ★ Bowl
- ★ Weights, marbles or similar for testing strength of structure
- ★ Card

One day, astronauts could build houses on the Moon harnessing the energy from the Sun and using the Moon's own soil called 'regolith'. The European Space Agency (ESA) has recently conducted an experiment, making 3D-printed bricks from a volcanic material of similar composition to lunar dust and baking them at temperatures of 1,000°C in a solar furnace. The bricks had the strength of the mineral gypsum used in plaster. Although mechanical testing has not been completed, the ESA is convinced that future inhabitants of the Moon could use locally sourced building materials, thus avoiding the need to transport them from Earth.

In these activities, the children make structures from simple ingredients, investigate a variety of recipes and conduct stress tests to determine which produces the strongest bricks.



Image ESA

★ ADVANCE PREPARATION

Role badges for **space engineer**, Appendix 1

Drying time, up to a day or two, is required after mixing ingredients and putting the mixtures into cups or moulds, before stress tests can be performed

★ INTRODUCTION

The children watch a short video from the European Space Agency showing building of a lunar village taking place:

http://www.esa.int/esatv/Videos/2016/03/Moon_Village2/Animation_Moon_Village_Construction_-_Credit_Foster_Partners

Using the lunar soil or 'regolith' scooped by a lunar rover as building material, 3D printing can take place avoiding the need to transport materials from Earth. Explain that although there is no atmosphere on the Moon, so buildings would not be eroded by wind or rain, there are other dangers that must be considered. The lunar surface is bombarded by meteoroids that break lunar rock into pieces. Engineers are testing bricks made from ingredients similar to real lunar soil for strength, before sending astronauts to the Moon.

Samples of Moon regolith have been brought back to Earth by astronauts but these are very precious and in short supply. So, in our tests, we are going to use sand, water and glue as a cheaper alternative. The groups will have recipe cards and instructions for making three mixtures. The mixtures will be placed in moulds (small disposable plastic cups or similar). Explain that they will have to test their mixtures for strength once the mixtures are dry. Ask the children to suggest ways in which they could test the strength of the structures.

What might engineers try?

The children mix the ingredients and place in the moulds, pressing the mixture flat before leaving them until they have dried. They might like to compare structures made using ice-cube trays and disposable cups as moulds. They must carefully remove the structures from the moulds and place first a piece of card and then a disposable cup on top of the structure. They can test the strength of each structure by placing in the cup small weights or objects such as nails or marbles, one at a time, increasing the load until the structure is damaged.

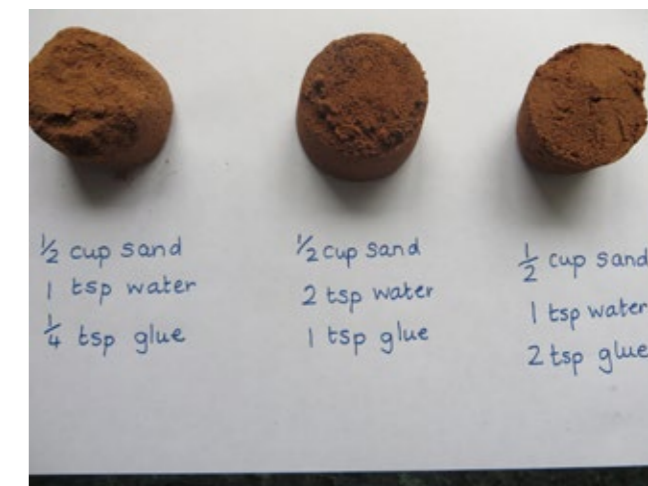

Image shows an example of lunar bricks made using plastic cups as moulds.

★ **PLENARY**

Discuss the results of the investigations.

*Which recipe produced the strongest structure?
What could you add to the recipe to increase the strength of the structures? If you used moulds of different shapes, could you improve the strength of the structures?*

Explain that engineers must choose the correct materials for the construction of a building.

Can the children think of materials used in buildings here on Earth?

Wood, steel and concrete are most often chosen. Concrete, a mixture of minerals, water, rocks and soils, is used because it can withstand erosion and is very strong.

What would the structures need to be able to withstand on the Moon?

Remind the children that erosion by wind and rain would not occur on the Moon but frequent bombardment with meteorites would be a consideration. Engineers ensure that structures are strong by using stress tests, adding weights to models and using computer simulation to measure how much the building can hold.

Conclude by watching a video clip of a challenge to design a lunar 'digger', capable of navigating the lunar surface and digging lunar regolith:
<https://nasaclips.arc.nasa.gov/video/realworld/archive-real-world-moon-dirt>

★ **EXTENSION**

The children devise recipes, for example, adding a different kind of glue or sand, to improve the strength of their structures and test them in a similar way.

Crystalline solids are found on the Moon.
Would adding a crystalline solid, such as salt or rock salt, improve the strength of the structure?

Plan a different strength test using different loads or by dropping objects onto the structures.

Try a variety of shapes or sizes for the moulds, testing the structures produced in a similar way.

Activity Sheet 12a ★ Building bricks stress test recipes

RECIPE A – THE CONTROL

- ½ cup of sand
- 1 to 2 teaspoons of water
- Mix
- Spoon into the mould
- Press gently
- Leave to dry

RECIPE B

- 1 teaspoon of water
- 2 teaspoons of glue
- Mix
- Add ½ cup of sand
- Mix
- Spoon into the mould
- Press gently
- Leave to dry

RECIPE C

- 2 teaspoons of water
- 1 teaspoon of glue
- Mix
- Add ½ cup of sand
- Mix
- Spoon into the mould
- Press gently
- Leave them to dry

RECIPE D

- 1 teaspoon water
- ¼ teaspoon glue
- Mix
- Add ½ cup sand
- Mix
- Spoon into the mould
- Leave to dry

TEST FOR STRENGTH

- Once it has dried, carefully take the mixture out from the mould
- Place a piece of card on top of the 'brick'
- Place a paper cup on top of the card
- Add weights to the cup until the test brick crumbles
- How many weights did you add?

YOUR RECIPE

Plan your own recipe to make the building material. You could use some or all of these:

- Sand
- Water
- Glue
- Flour
- Salt
- Mix and place in moulds
- Press mixture gently
- Leave to dry

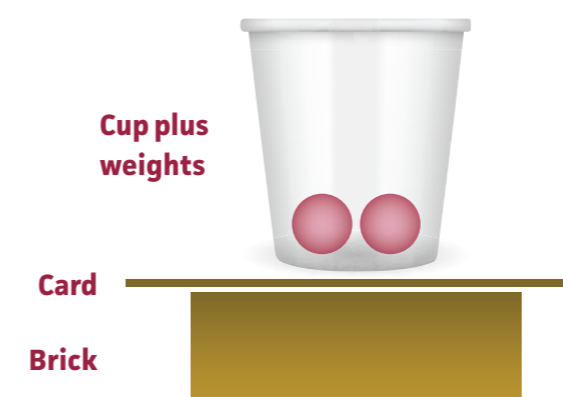

Appendix 1 ★ Role Badges

Children, working in groups of four, each wear a role badge and take on responsibility for a particular task.

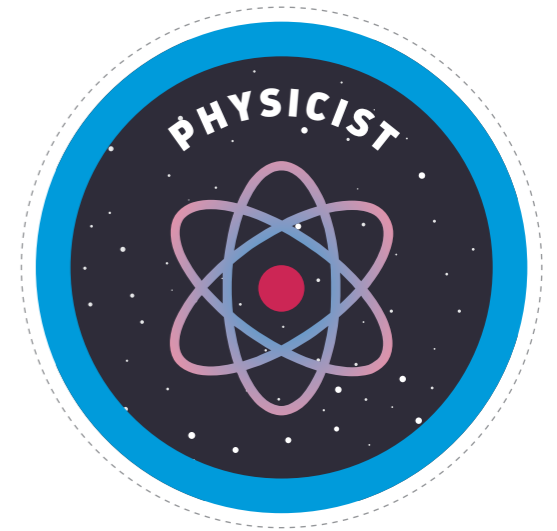
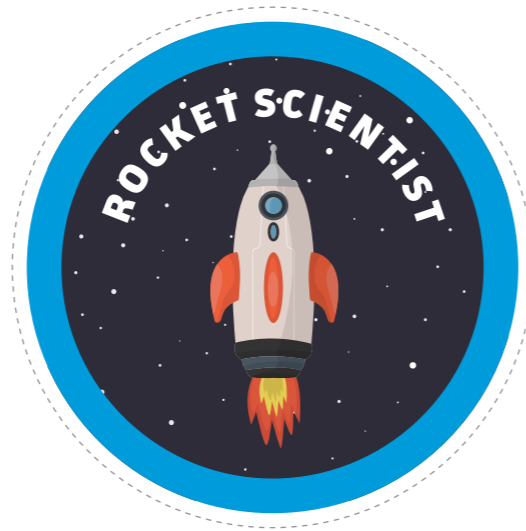

Appendix 2 ★ Biographies

★ PROFESSOR ANDY NEWSAM, ASTRONOMER

Andy grew up interested in almost everything, and chose to become a scientist so he could spend the rest of his life answering interesting questions. He did a degree where he studied physics and learnt how to use computers to help him. After that, he became particularly interested in the science of the stars and planets and so on, and so became an astronomer. He still spends a lot of time trying to understand the universe, using telescopes in different parts of the world and sometimes in orbit around it! He also enjoys sharing the excitement of astronomy with as many people as possible, including schools through the National Schools' Observatory project, which he helped to set up and run.



★ PROFESSOR HANNAH SARGEANT, LUNAR GEOLOGIST

I've always had a passion for learning about space and it was my dream to work as a space scientist. Even now I love watching movies about space! To get to where I am today I studied science and maths in school and then at college. I then studied physics at university. Because I've always enjoyed science and working with young people, I then became a science teacher, which I loved. After a couple of years I decided to go back to university to chase my dream of working in the space industry. I did a Master's degree in Space Exploration Systems which taught me about space science and geology, and engineering. Now I am doing my PhD, which is part of a Moon mission, and I am using lots of skills including lunar geology, chemistry, physics and engineering.

Currently, I am looking at ways to create water from Moon rocks. If we want astronauts to be able to live

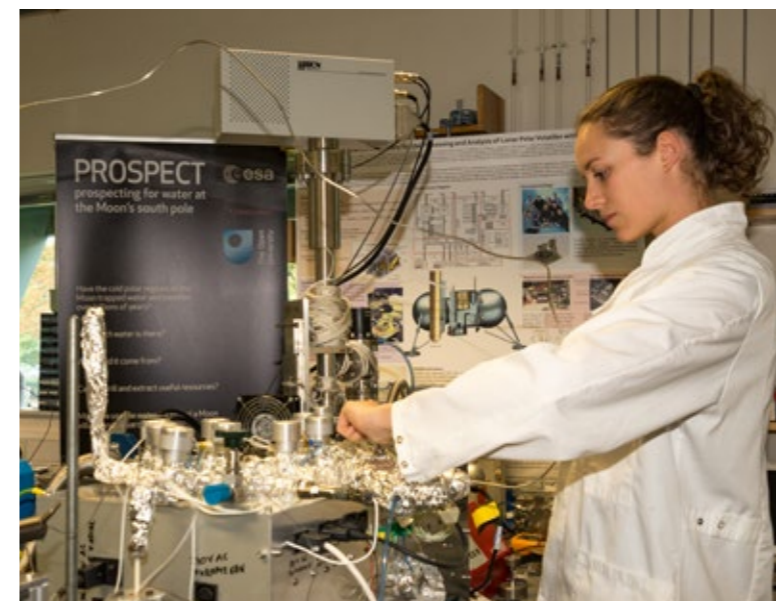

on the Moon for long missions we have to find water because it's just too expensive to bring all the supplies with us. However, the Moon is thought to be bone dry in most areas so we would have to find a way to create water from the rocks themselves. I am testing the best ways to create water from Moon rocks using chemical reactions. We have a mission going to the Moon in a few years' time and we will test whether my experiments will actually work on the Moon. An example of some of the work I will be doing is taking some ilmenite (a type of rock we know we can find on the Moon) and heating it up with hydrogen gas to make water. Next I will try and find the best technique to use to get the most amount of water.

One of the best parts of my job is that I get to travel to exciting places, either to conferences or to learn new skills. Conferences are great places to share work with other scientists doing similar things, and I have been able to attend conferences in Germany, France and the Netherlands. I have also been to training events in Belgium and I will be spending my summer at NASA in America where I will learn lots about lunar geology and help with NASA missions!

My favourite part about being a lunar scientist/ geologist is that every day is different. I am always learning something new and meeting exciting people. Also, studying for my PhD means I get to research something that has never been done before! If you would like to have a career in space science and geology then working hard in science class is very important. If you have a real passion for geology then geography can also be very useful. Remember that school is where your journey to being a scientist begins; it is in the classroom where you learn the key skills that you can then use to answer the biggest questions in the universe!

Appendix 3 ★ Story books and poems

'Whatever Next!' by Jill Murphy

'Man on the Moon' by Simon Bartram

Poem: 'Six Ways to Look at the Moon' by Pie Corbett

'Papa, Please Get the Moon for Me' by Eric Carle

'Here We Are' by Oliver Jeffers

'How to Catch a Star' by Oliver Jeffers

'The Way Back Home' by Oliver Jeffers

'If You Decide to Go To the Moon' by Faith McNulty

'One Giant Leap' by Robert Burleigh

'Owl Moon' by Jane Yolen

'Moon Man' by Tomi Ungerer

Appendix 4 ★ Moon trivia quiz

Each team discusses and gives answers. Score each team. Re-do the quiz at intervals to see progress.
(Provide one copy with bold font for the teacher, one without bold font for children)

QUESTIONS	ANSWERS (teacher copy)
What does the Earth have that the Moon does not?	<ul style="list-style-type: none"> • Mountains • Rocks • Gravity • Atmosphere
How many days does the Moon take to orbit the Earth?	<ul style="list-style-type: none"> • 27.3 days • It doesn't orbit the Earth • 365 days • 31 days
When was the Moon made?	<ul style="list-style-type: none"> • 3.5 billion years ago • 4.5 billion years ago • 2.5 billion years ago • 1 billion years ago
What is the average temperature on the Moon?	<ul style="list-style-type: none"> • 100°C • -173°C • -247°C • -173°C at night to +127°C in day
What causes the Earth's tides?	<ul style="list-style-type: none"> • Tilting of Earth • Sun's gravity • Amount of water in the ocean • Gravity of Moon and Sun
How was the Moon's dust made?	<ul style="list-style-type: none"> • From space junk • From dust on Earth • From asteroids and meteoroids crashing onto its surface • From Earth's atmosphere

QUESTIONS	ANSWERS (teacher copy)
Which of these is NOT a shape of the Moon?	<ul style="list-style-type: none"> • Gibbous • Crescent • Full • String
The Moon's mass is about?	<ul style="list-style-type: none"> • 1/100 Earth's mass • 1/20 Earth's mass • 1/50 Earth's mass • 1/15 Earth's mass
A person weighing 60kg on Earth would weigh how much on the Moon?	<ul style="list-style-type: none"> • 10kg • 20kg • 60kg • 15kg
A day (sunrise to the next sunrise) on the Moon is?	<ul style="list-style-type: none"> • 24 hours • 48 hours • 126 hours • 708 hours
What percentage of the Moon's surface can we see from Earth?	<ul style="list-style-type: none"> • 50% • 59% • 76% • 100%
Which statement is TRUE?	<ul style="list-style-type: none"> • The Moon has a thin atmosphere with few clouds • The Moon does not have an atmosphere • The Moon has a thin atmosphere but no clouds
The surface of the Moon is called?	<ul style="list-style-type: none"> • Apollo • Regolith • Moonzonite • Craters

QUESTIONS	ANSWERS (teacher copy)
How many people have walked on the Moon?	<ul style="list-style-type: none"> • 8 • 12 • 22 • 16
Compared with earthquakes, Moonquakes are...	<ul style="list-style-type: none"> • A million times weaker • Same intensity • Stronger than earthquakes • Much stronger than earthquakes
How far is the Moon from Earth?	<ul style="list-style-type: none"> • 5,280 miles (8,497km) • 186,00 miles (299,338 km) • 238,855 miles (384,400km)
The largest mare on the Moon is?	<ul style="list-style-type: none"> • Mare Imbrium (Sea of Showers) • Mare Nubium (Sea of Clouds) • Mare Tranquilitas (Sea of Tranquility)
The Moon's soil is?	<ul style="list-style-type: none"> • Fragments of dead organisms that used to live on the Moon • Sand very similar to sand on Earth • Not actually soil because there is no living matter on the Moon
The density of the Moon is	<ul style="list-style-type: none"> • Almost identical to the density of the Earth • About twice the density of the Earth • Less than the density of the Earth
The Moon had active volcanoes	<ul style="list-style-type: none"> • About 3.7 to 2.5 billion years ago • 4.5 to 3.9 billion years ago • 2.4 to 1.6 billion years ago

QUESTIONS	ANSWERS (teacher copy)
If the Moon passes through the part of the Earth's shadow called the umbra, it will cause	<ul style="list-style-type: none"> • A partial lunar eclipse • A total lunar eclipse • A total solar eclipse
Approximately how long does it take for the Moon to orbit the Sun?	<ul style="list-style-type: none"> • 1 day • 1 month • 1 year
Why do we only ever see one side of the Moon?	<ul style="list-style-type: none"> • We never watch it long enough • The Moon is a flat circle; there is no other side • The Moon takes the same length of time to spin around once as it takes to orbit the Earth • We don't just see one side
How strong is the Moon's gravity?	<ul style="list-style-type: none"> • Six times weaker than Earth's • Same as Earth's • Six times stronger than Earth's
Where do most scientists think the Moon came from?	<ul style="list-style-type: none"> • A small planet caught in the Earth's gravity • Debris from a planet the size of Mars that crashed into Earth • Just gas reflecting light from Venus
The Moon is slowly moving away from the Earth every year by how much?	<ul style="list-style-type: none"> • 4cm • 4m • 400m
When did an astronaut first walk on the Moon?	<ul style="list-style-type: none"> • 1968 • 1969 • 1996
Who was the second astronaut to walk on the Moon?	<ul style="list-style-type: none"> • Buzz Aldrin • Michael Collins • Neil Armstrong

QUESTIONS	CHILDREN'S CARDS
What does the Earth have that the Moon does not?	<ul style="list-style-type: none"> • Mountains • Rocks • Gravity • Atmosphere
How many days does the Moon take to orbit the Earth?	<ul style="list-style-type: none"> • 27.3 days • It doesn't orbit the Earth • 365 days • 31 days
When was the Moon made?	<ul style="list-style-type: none"> • 3.5 billion years ago • 4.5 billion years ago • 2.5 billion years ago • 1 billion years ago
What is the average temperature on the Moon?	<ul style="list-style-type: none"> • 100°C • -173°C • -247°C • -173°C at night to +127°C in day
What causes the Earth's tides?	<ul style="list-style-type: none"> • Tilting of Earth • Sun's gravity • Amount of water in the ocean • Gravity of Moon and Sun
How was the Moon's dust made?	<ul style="list-style-type: none"> • From space junk • From dust on Earth • From asteroids and meteoroids crashing onto its surface • From Earth's atmosphere

QUESTIONS	CHILDREN'S CARDS
Which of these is NOT a shape of the Moon?	<ul style="list-style-type: none"> • Gibbous • Crescent • Full • String
The Moon's mass is about?	<ul style="list-style-type: none"> • 1/100 Earth's mass • 1/20 Earth's mass • 1/50 Earth's mass • 1/15 Earth's mass
A person weighing 60kg on Earth would weigh how much on the Moon?	<ul style="list-style-type: none"> • 10kg • 20kg • 60kg • 15kg
A day (sunrise to the next sunrise) on the Moon is?	<ul style="list-style-type: none"> • 24 hours • 48 hours • 126 hours • 708 hours
What percentage of the Moon's surface can we see from Earth?	<ul style="list-style-type: none"> • 50% • 59% • 76% • 100%
Which statement is TRUE?	<ul style="list-style-type: none"> • The Moon has a thin atmosphere with few clouds • The Moon does not have an atmosphere • The Moon has a thin atmosphere but no clouds
The surface of the Moon is called?	<ul style="list-style-type: none"> • Apollo • Regolith • Moonzonite • Craters

QUESTIONS	CHILDREN'S CARDS
How many people have walked on the Moon?	<ul style="list-style-type: none"> • 8 • 12 • 22 • 16
Compared with earthquakes, Moonquakes are...	<ul style="list-style-type: none"> • A million times weaker • Same intensity • Stronger than earthquakes • Much stronger than earthquakes
How far is the Moon from Earth?	<ul style="list-style-type: none"> • 5,280 miles (8,497km) • 186,00 miles (299,338 km) • 238,855 miles (384,400km)
The largest mare on the Moon is?	<ul style="list-style-type: none"> • Mare Imbrium (Sea of Showers) • Mare Nubium (Sea of Clouds) • Mare Tranquilitas (Sea of Tranquility)
The Moon's soil is?	<ul style="list-style-type: none"> • Fragments of dead organisms that used to live on the Moon • Sand very similar to sand on Earth • Not actually soil because there is no living matter on the Moon
The density of the Moon is	<ul style="list-style-type: none"> • Almost identical to the density of the Earth • About twice the density of the Earth • Less than the density of the Earth
The Moon had active volcanoes	<ul style="list-style-type: none"> • About 3.7 to 2.5 billion years ago • 4.5 to 3.9 billion years ago • 2.4 to 1.6 billion years ago

QUESTIONS	CHILDREN'S CARDS
If the Moon passes through the part of the Earth's shadow called the umbra, it will cause	<ul style="list-style-type: none"> • A partial lunar eclipse • A total lunar eclipse • A total solar eclipse
Approximately how long does it take for the Moon to orbit the Sun?	<ul style="list-style-type: none"> • 1 day • 1 month • 1 year
Why do we only ever see one side of the Moon?	<ul style="list-style-type: none"> • We never watch it long enough • The Moon is a flat circle; there is no other side • The Moon takes the same length of time to spin around once as it takes to orbit the Earth • We don't just see one side
How strong is the Moon's gravity?	<ul style="list-style-type: none"> • Six times weaker than Earth's • Same as Earth's • Six times stronger than Earth's
Where do most scientists think the Moon came from?	<ul style="list-style-type: none"> • A small planet caught in the Earth's gravity • Debris from a planet the size of Mars that crashed into Earth • Just gas reflecting light from Venus
The Moon is slowly moving away from the Earth every year by how much?	<ul style="list-style-type: none"> • 4cm • 4m • 400m
When did an astronaut first walk on the Moon?	<ul style="list-style-type: none"> • 1968 • 1969 • 1996
Who was the second astronaut to walk on the Moon?	<ul style="list-style-type: none"> • Buzz Aldrin • Michael Collins • Neil Armstrong

NOTES

NOTES



National STEM Learning Centre
University of York
Heslington
York YO10 5DD

+44 (0) 1904 328300
www.stem.org.uk/esero